

PRODUCER OF SANDWICH PANELS

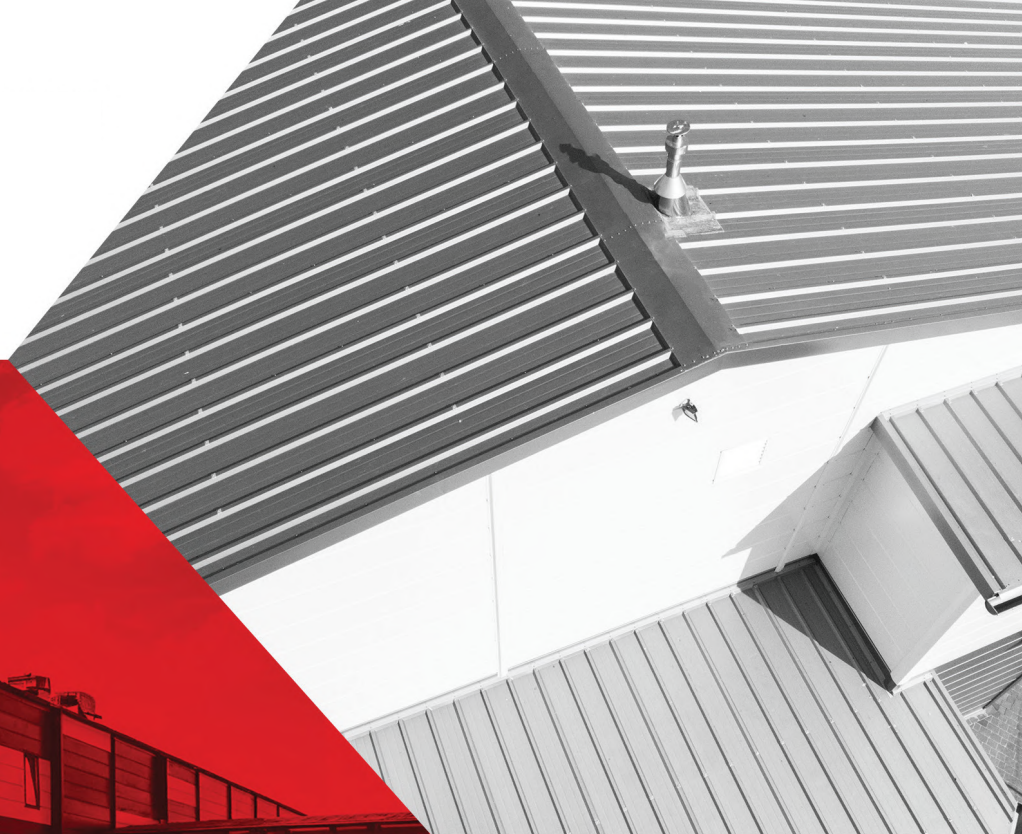

PRACTICAL GUIDE

BY PRODUCTS AND
ACCESSORIES

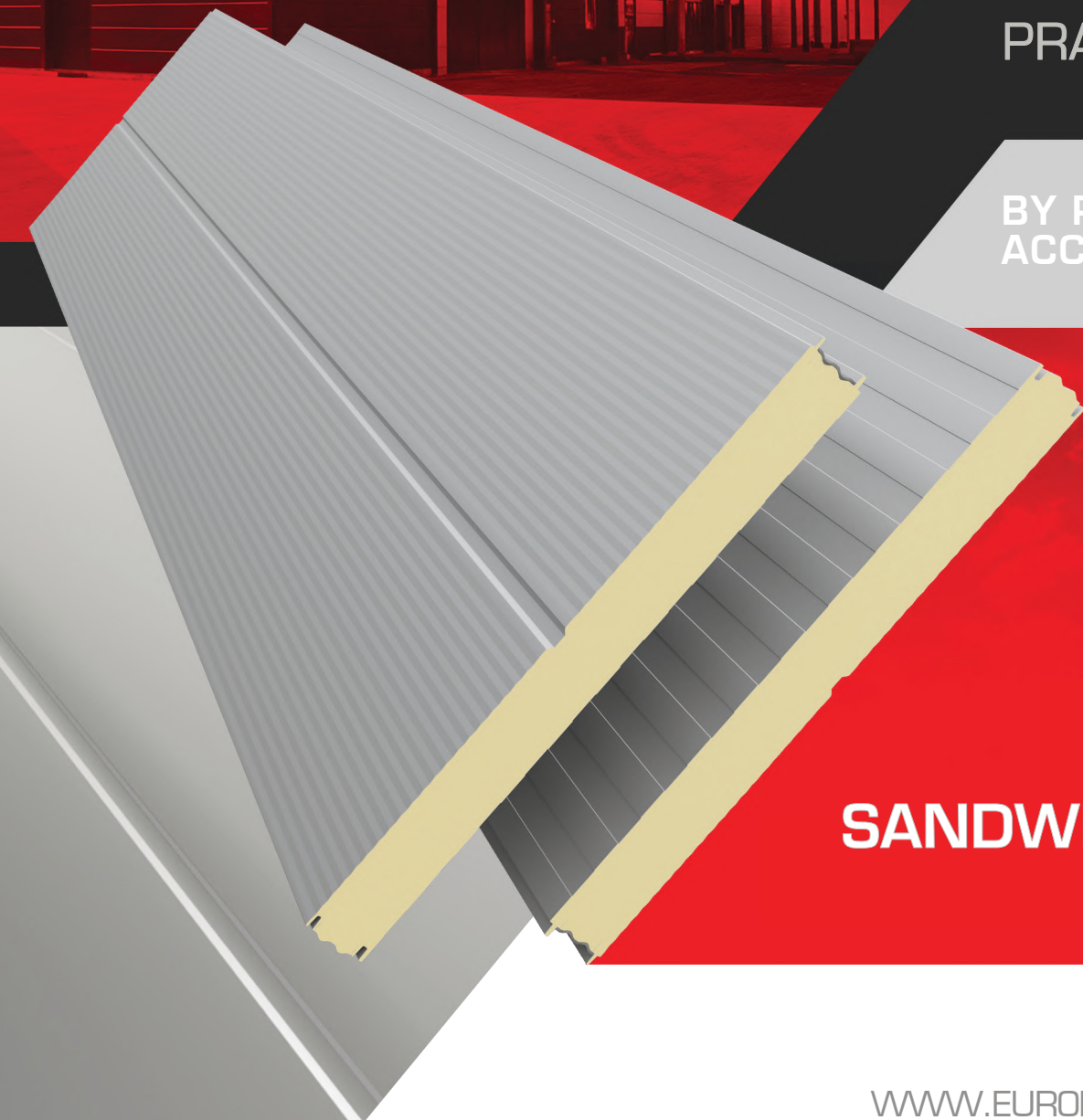

European

SANDWICH PANELS

WWW.EUROPANELS.PL/EN/

CONTENTS

- 3 Introduction
- 4 About the technology
- 5 Basic recommendations
- 6 Training
- 7 Knowledge base
- 8 Before you order

PU WALL PANELS

- 10 PolTherma DS
- 14 PolTherma PS
- 18 Panel installation instructions
- 21 PolTherma TS
- 24 PolTherma TS X
- 26 Panel installation instructions
- 28 PolTherma CS
- 32 PolTherma CS X

PU ROOFING SHEETS

- 34 PolDeck TD
- 38 Panel installation instructions
- 42 PolDeck MD

EPS WALL PANELS

- 46 ThermaStyle PRO
- 50 Panel installation instructions

EPS ROOFING SHEETS

- 52 ThermaDeck PRO
- 56 Panel installation instructions
- 58 Sheet metal flashing
- 72 Cladding colors
- 74 Innovative cladding colors



Europanel Sp. z o.o. is a dynamic and modern enterprise offering its clients lightweight wall and roof cladding systems, along with a full range of finishing and installation accessories. Our product portfolio includes sandwich panels featuring polyurethane (PU) and polystyrene (EPS) cores. We have specialized in this product sector for many years, and our products have earned the recognition of clients across numerous European markets. They have also garnered acclaim from industry professionals.

Our family of wall sandwich panels with PU insulation cores was awarded a Gold Medal at the 17th International Agricultural Technology Fair (AGROTECH) in Kielce for the best product in the field of agricultural construction. The PolTherma DS wall sandwich panel system—unique within the European market—was honored with a prestigious Gold Medal at the 20th International Construction Fair (BUDMA) in Poznań for the best product in industrial construction.

Europanel sandwich panels represent a modern construction material designed for use as external and internal walls, roofing, and suspended ceilings. These products embody contemporary technology, offering a host of benefits: from rapid and easy installation (reducing project completion times and total investment costs) to operational savings throughout the building's lifecycle (thanks to excellent thermal insulation parameters).

This brochure presents a cross-section of the Europanel product range, focusing on sandwich panels and installation accessories. It is crucial to utilize our system-based accessory solutions, which have been specifically engineered to ensure optimal component fit and adherence to rigorous technological standards. For your convenience, this brochure contains general guidelines—presented in both graphic and descriptive formats—that illustrate a sample installation process. In this way, the brochure serves as a practical guide to assist you during product installation. Through this format, our aim is to demonstrate how you can easily, quickly, correctly, and safely construct impressive structures using our panels.

Europanel reserves the right to manufacture sandwich panels within the technical tolerances specified on page 4. Compliance with these tolerances—regardless of visual appearance—shall not be deemed a product defect.

Detailed installation instructions, recommendations, and General Terms and Conditions of Sale are available at www.europanel.pl/en/download/.



Europanel manufactures sandwich panels that meet the requirements of the European standard PN-EN 14509:2013-2012: "Self-supporting double-skin metal-faced insulating sandwich panels — Factory-made products — Specifications."

The CE marking confirms compliance with European standards for quality and operational safety. Nevertheless, as technical products manufactured in accordance with these standards, they are subject to certain tolerances, as defined within the standards themselves:



Dimension	Tolerance (maximum permissible)
Sandwich panel thickness ^a	$D \leq 100 \text{ mm} \pm 2 \text{ mm}$ $D > 100 \text{ mm} \pm 2 \%$
Deviation from flatness (as measured over length L)	For L = 200 mm - Deviation from flatness 0,6 mm For L = 400 mm - Deviation from flatness 1,0 mm For L > 700 mm - Deviation from flatness 1,5 mm
Height of the metal profile (rib) (mm)	$5 < h \leq 50 \text{ mm} \pm 1 \text{ mm}$ $50 < h \leq 100 \text{ mm} \pm 2,5 \text{ mm}$
Height of stiffeners and light-gauge profile	$d_s \leq 1 \text{ mm} \pm 30\% \text{ od } d_s$ $1 \text{ mm} < d_s \leq 3 \text{ mm} \pm 0,3 \text{ mm}$ $3 \text{ mm} < d_s \leq 5 \text{ mm} \pm 10\% \text{ od } d_s$
Sandwich panel length	$L \leq 3 \text{ m} \pm 5 \text{ mm}$ $L > 3 \text{ m} \pm 10 \text{ mm}$
Sandwich panel coverage width	$w \pm 2 \text{ mm}$
Deviation from perpendicularity	$0,006 \times w$ (nominal coverage width)
Deviation from straightness (over length)	1 mm per meter, maximum 5 mm
Bend	2 mm per meter of length, maximum 20 mm. 8.5 mm per meter of width for flat or slightly profiled surfaces - $h \leq 10 \text{ mm}$ 10 mm per meter of profile width - $h > 10 \text{ mm}$
Profile step (p)	For $h \leq 50 \text{ mm}$ $p: \pm 2 \text{ mm}$ For $h > 50 \text{ mm}$ $p: \pm 3 \text{ mm}$
Rib width (b_1) and valley width (b_2)	For $b_1 \pm 1 \text{ mm}$ For $b_2 \pm 2 \text{ mm}$

^a Calculation of Sandwich Panel Thickness with Profiled Cladding



Sandwich panels with steel facings are a durable material; however, they are susceptible to mechanical damage. Please exercise particular care—for instance, during unloading or installation—to prevent them from being broken or scratched. We recommend the use of professional transport and installation equipment.

Panels should be cut exclusively using appropriate tools—such as a circular saw (not an angle grinder!)—while directing the stream of sparks away from the surface of the panel being cut, as well as away from any panels that have already been installed. This will prevent the deposition of rapidly corroding metal filings onto the facing surface.

Panels should be stored on a level, stable, and moisture-free surface. The panels should rest on polystyrene spacers; furthermore, in cases of prolonged storage—and invariably during the summer months—the bundles must be protected from direct sunlight by covering them with a UV-resistant tarpaulin.

Due to the significant heat absorption of facade facings caused by exposure to sunlight, we recommend selecting colors from Color Group I (very light colors) and limiting the length of individual panel sections (optimally to 7 meters). For wall panels, we recommend single-span horizontal layouts, fastened to columns spaced—for example—at 6-meter intervals (center-to-center).

The selection of panel types and the installation method must be consistent with the construction design and the technical specifications of the panels. The spacing of supports, the characteristics of load-bearing profiles, load calculations, the quantity of fasteners, final material selection, etc., are determined by the project designer. European sandwich panels are available to everyone. We invite you to build with us.

The Europanel Sp. z o.o. Team



TRAINING, WORKSHOPS, CONSULTATIONS

Europanel is more than just products; it is also a team of experienced and passionate specialists who form the very core of our company. We believe that building long-term relationships is the key to achieving success. That is precisely why we offer our clients support at every stage of project implementation.

We organize product training sessions and industry workshops designed to help installation firms enhance their knowledge and skills regarding the installation of the modern building materials we manufacture.

We have regional representatives located in every corner of Poland who are ready to assist—not only by helping you select the right product and appropriate accessories, but also by recommending proven local installation firms, and by doing everything in their power to ensure that every project is a success.

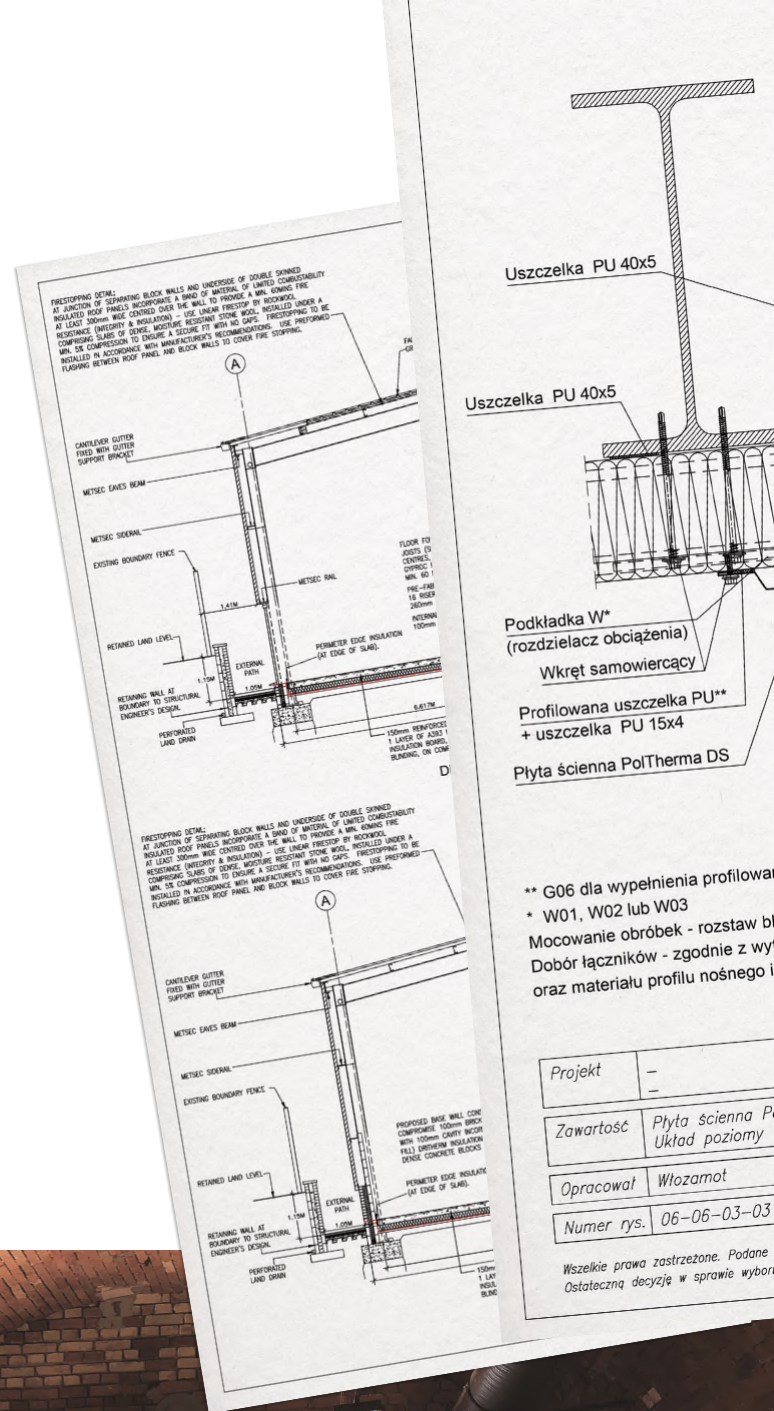

KNOWLEDGE BASE

For our clients and contractors, we provide comprehensive information designed to assist in making strategic decisions during the design and construction phases involving the use of our products. Digital versions are available on our website at www.europanel.pl/en/, while printed brochures can be obtained from our representatives.

Materials that may prove useful to you include, among others:

Catalog



General Terms and Conditions of Sale

-



Technical Data Sheets

-



Board Assembly Instructions

-



Sheet Metal Flashing Catalogs

-



Certificates and Approvals

-



Load Tables

-



Detail Library

-



BIM Library

-



BEFORE YOU ORDER WALL PANELS

The wall sandwich panels offered by Europanel constitute an ideal material for the rapid, cost-effective, and lightweight cladding of industrial halls. They create aesthetically appealing and functional wall facades. To select the appropriate panels for a specific application, the following parameters should be considered:

- thermal insulation requirements (heat transfer coefficient)
- determination of the panel layout on the building (horizontal or vertical) and the span lengths
- determination of the exact length of individual panels (the responsibility of the ordering party)
- selection of the installation method (in-house or with the assistance of a specialized installation firm)
- aesthetics — the architectural concept (selection of profiling, color, and accessories).

Due to the construction of sandwich panels and the variety of operating conditions, it is recommended to use the shortest possible individual panel lengths (optimally up to 7 m) and—whenever feasible—to fasten the panels to the structure using a horizontal, single-span arrangement.

Advantages of a horizontal, single-span slab arrangement:

- Optimization of technical parameters – due to structural considerations, panels in shorter sections—acting as single-span elements—effectively compensate for operational (thermal) stresses.
- Improved material utilization – the ability to incorporate continuous window strips without the need to cut the panels.
- More cost-effective load-bearing structures – columns constructed from steel, timber, or reinforced concrete.
- Enables the use of lightweight structures – columns anchored to footings.
- No additional costs – eliminates the need for wall girts.
- Simplified panel installation – attachment required only to the load-bearing columns.
- Easier unloading and transport of panels onto the structure.

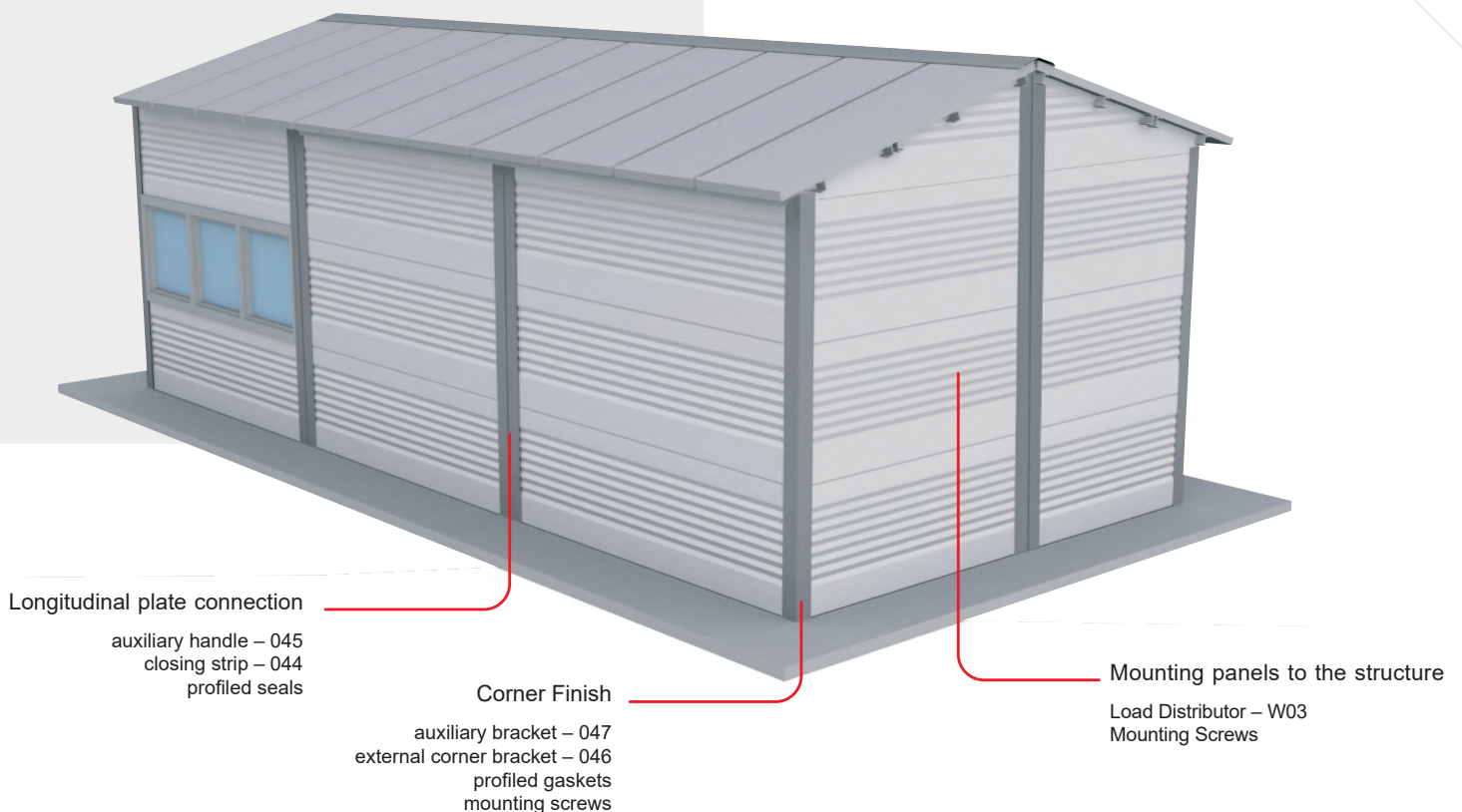

The traditional method for installing PolTherma DS wall panels involves the use of Z-profiles attached to structural columns, serving as supporting elements for the panels.

As an alternative installation method, we propose mounting the panels directly onto the sill beam using L-profiles attached to the beam, which serve as the supporting structure for the panels.

A crucial aspect of the installation process is ensuring that the sill beam is level and uniform across its entire mounting surface.

During installation, it is essential to utilize horizontal insulation, as well as an impregnated PU gasket or mounting foam, to fill the gap between the thermal insulation of the sill beam—or the beam itself—and the contact surface between the panel joint and the supporting structure.

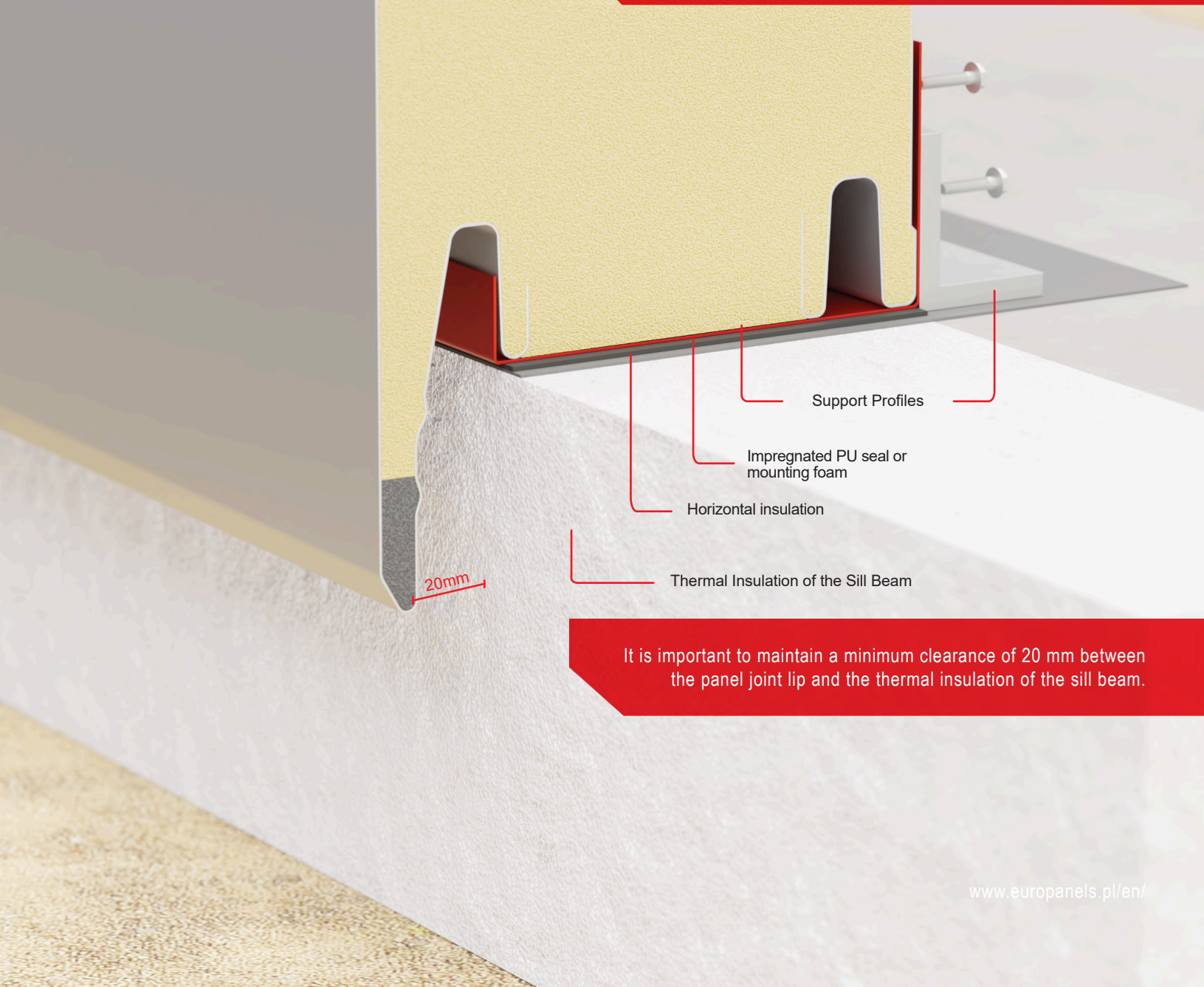

It is important to maintain a minimum clearance of 20 mm between the panel joint lip and the thermal insulation of the sill beam.

PolTherma DS

PREMIUM PANEL





PolTherma DS

PREMIUM PANEL

PolTherma DS is a wall sandwich panel featuring a rigid polyurethane foam (PU) core, attached to the supporting structure using an invisible fastening method (known as a "hidden joint"). Its installation requires the use of a special washer and screws, which are concealed by the overlapping panel once the connection is made. Consequently, the building's façade remains free of any visible fasteners, presenting a seamless expanse of elegant profiling.

Panel cross-section

1025 mm



Available panel thicknesses [mm]

60	80	100	120	160
----	----	-----	-----	-----

Thermal conductivity coefficient λ_D [W/(m·K)]

0.022

Heat transfer coefficient U_d, S for profiling S [W/(m²·K)]

0.46	0.32	0.25	0.20	0.15
------	------	------	------	------

Heat transfer coefficient U_d, S for profiling K and MK [W/(m²·K)]

0.44	0.31	0.24	0.20	0.15
------	------	------	------	------

Mass 1 m² [kg]

11.5	12.3	13.0	13.8	15.3
------	------	------	------	------

Maximum number of discs per pack [pcs]

18	14	11	9	7
----	----	----	---	---

Plate joint cross-section

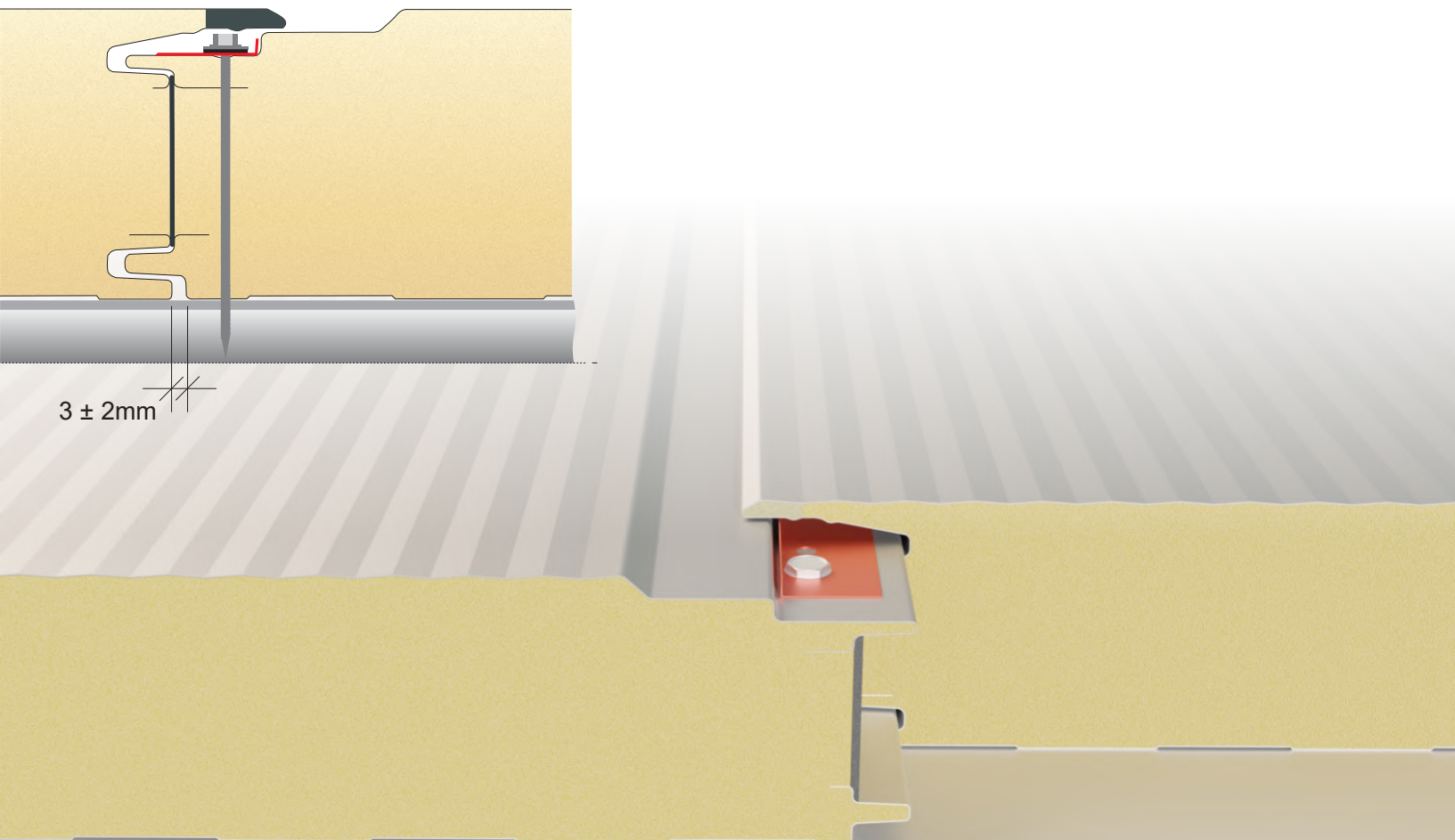
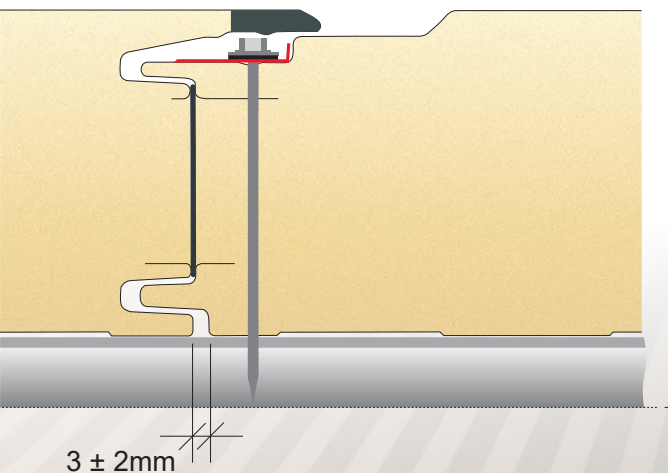

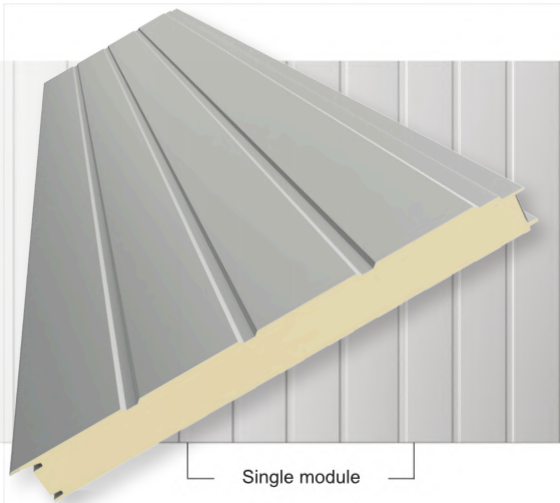

Cassette
K250

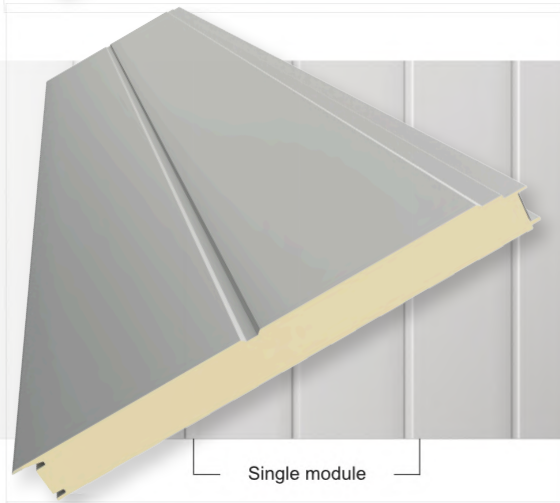

Cassette
K500

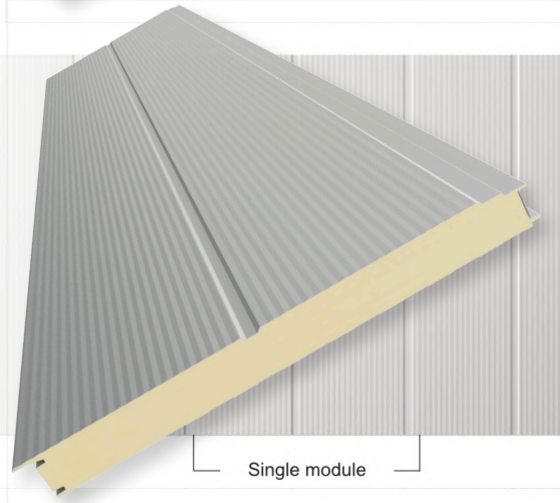

Mikro-cassette
MK500

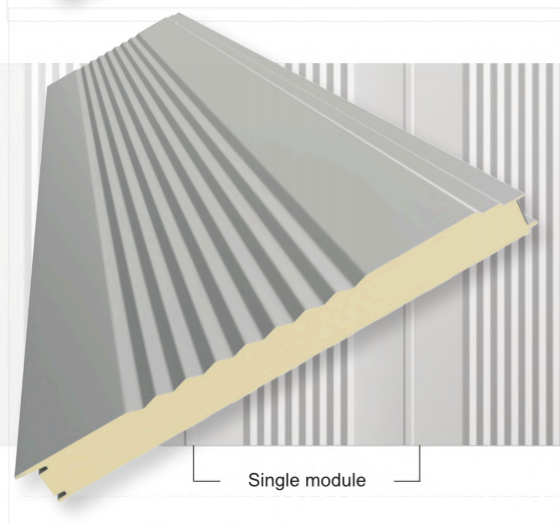

Slanted
S

PolTherma PS





PolTherma PS

PolTherma PS is a wall sandwich panel featuring a rigid polyurethane (PU) foam core, attached to the supporting structure via an invisible fastening method (known as a "hidden joint"). Its installation requires the use of a specialized washer and screws, which are concealed by the overlapping panel once the connection is made.

The PolTherma PS panel is a highly popular product, favored by clients who demand high aesthetic standards combined with standard profiling.

Unlike other hidden-joint PU wall panels in our product range, the lip concealing the joint of the PolTherma PS panel overlaps the adjacent panel without any visible seam. This design allows for the creation of a seamless expanse of elegant profiling across the entire façade.

Panel cross-section

1025 mm



Available panel thicknesses [mm]

60	80	100	120	160
----	----	-----	-----	-----

Thermal conductivity coefficient λD [W/(m·K)]

0.022

Heat transfer coefficient λD [W/(m²·K)]

0.39	0.29	0.23	0.19	0.14
------	------	------	------	------

Mass 1 m² [kg]

11.5	12.3	13.0	13.8	15.3
------	------	------	------	------

Maximum number of discs per pack [pcs]

18	14	11	9	7
----	----	----	---	---

Plate joint cross-section

3 ± 2mm

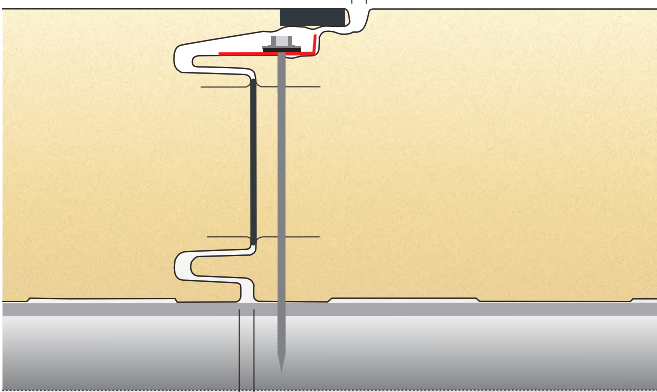

3 ± 2mm

Microprofiling
M

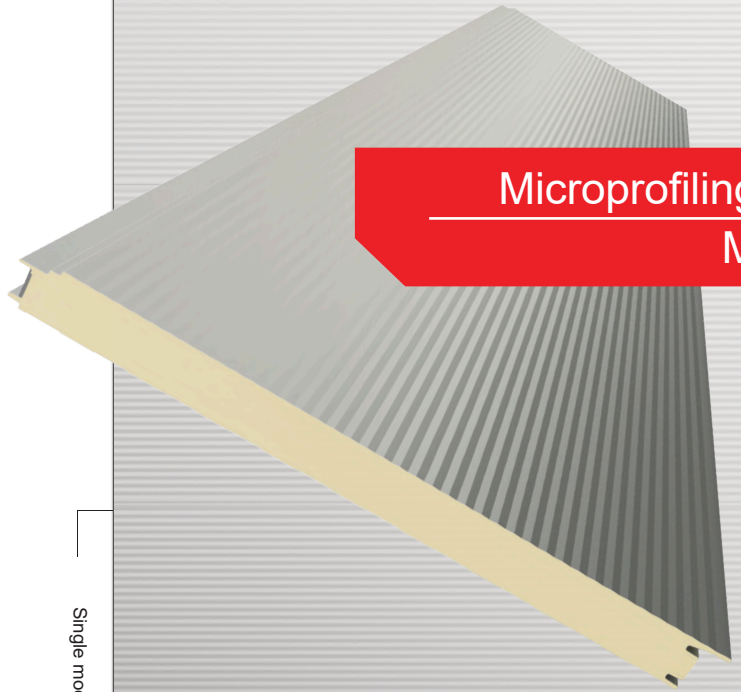

Single module

Single module

Linear
L

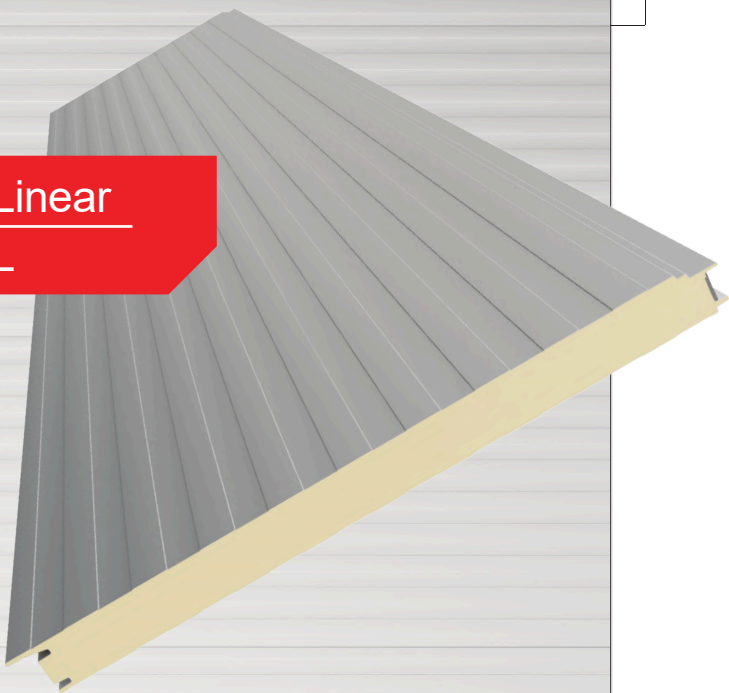

1. PREPARATION FOR BOARD INSTALLATION

1.1. Selection and Installation of the Starter Z-Profile

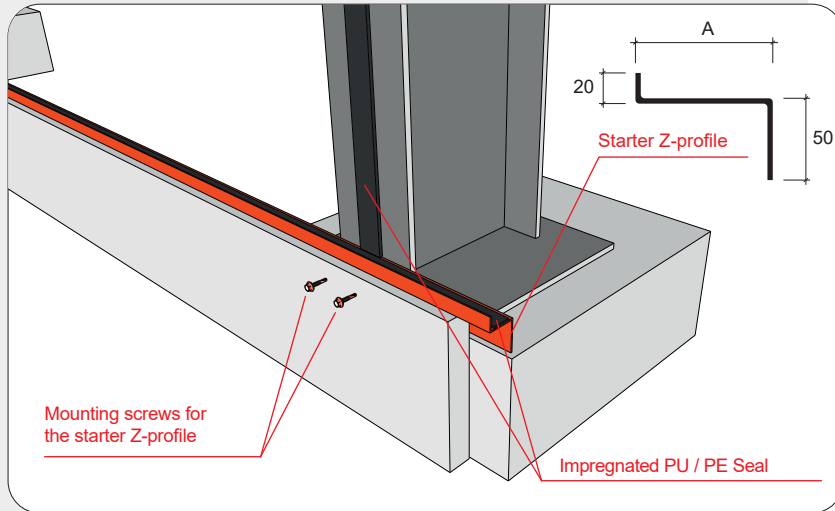

1.2. Installation of the skirting board

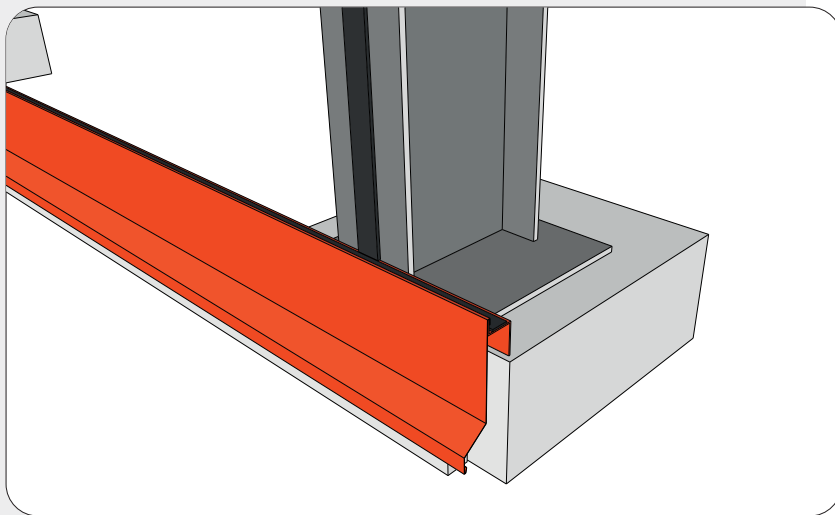

1.3. Mounting of the wall panel on a Z-purlin with flashing

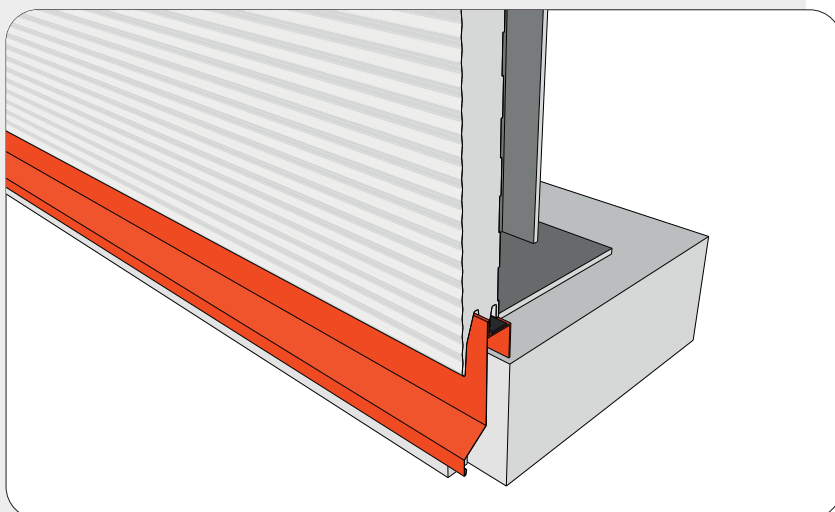

In a horizontal panel arrangement, no casing girts are required. The panels are fastened to the outer flange of the main load-bearing columns, passing through both facings. To establish a stable starting base for the first panel, the use of a starter Z-profile is recommended. The Z-profile is individually tailored to the thickness and type of the specific panel.

Starter Z-profile dimensions:

PolTherma DS/PS	
Slab thickness D [mm]	A [mm]
50	32
60	42
80	62
100	82
120	102
160	142

PolTherma TS/CS	
Slab thickness D [mm]	A [mm]
40	32
50	42
60	52
80	72
100	92
120	112
160	152
200	192

The Z-profile is typically manufactured from 2.0 mm thick sheet metal and is available as a standard item in 6-meter lengths.

The Z-profile is fastened with screws to posts, concrete blocks, plinth edges, etc., depending on the type of substrate. It should form a continuous line along the entire length of the wall. Once installed, a PU- or PE-impregnated seal is adhered to the horizontal flange of the Z-profile.

The proposed solution incorporates flashing element 058 (a plinth strip), which ensures that water is drained from the facade away from the foundation base (the foundation footing or plinth). This is of particular importance when thermal insulation is applied to the plinth. In this way, the substrate is protected against excessive moisture ingress caused by rainwater.

Flashing element 058a (for TS/CS panels) or 058b (for DS/PS panels) is fitted over the vertical edge of the starter Z-profile. This flashing element is not mechanically fastened. The overlap at the joints between individual sections is minimal (ideally, only the upper edge of the strip should be trimmed/cut before sliding it into place), or there is no overlap at all.

ATTENTION:

In the case of TS/CS panels, at the contact point of the first panel—which is to be seated on the starter profile—the "bulges" in the PU core must be trimmed away to ensure the contact surface aligns flush with the profile. The wall panels are ultimately seated with their outer tongue edge onto the flanged Z-profile and are mechanically fastened to the load-bearing columns using self-drilling screws.

It is recommended to fasten TS/CS panels using a through-fastening method—penetrating both facings—with a minimum of two screws per side (three screws at corners), resulting in a total of four screws (six at corners) per panel. DS/PS panels are typically fastened using a set of washers known as load distributors, utilizing two screws per washer at each fastening point. However, if the support flange on the column is narrow, DS/PS panels may alternatively be fastened in a manner similar to TS/CS panels; in this instance, however, the fasteners must be positioned within the full-thickness sections of the panel (rather than within the recessed ribs).

2. INSTALLATION OF DS AND PS SERIES PANELS TO STEEL STRUCTURES

2.1. Panel Mounting with Concealed Joints – Vertical Arrangement (PolTherma DS and PS)

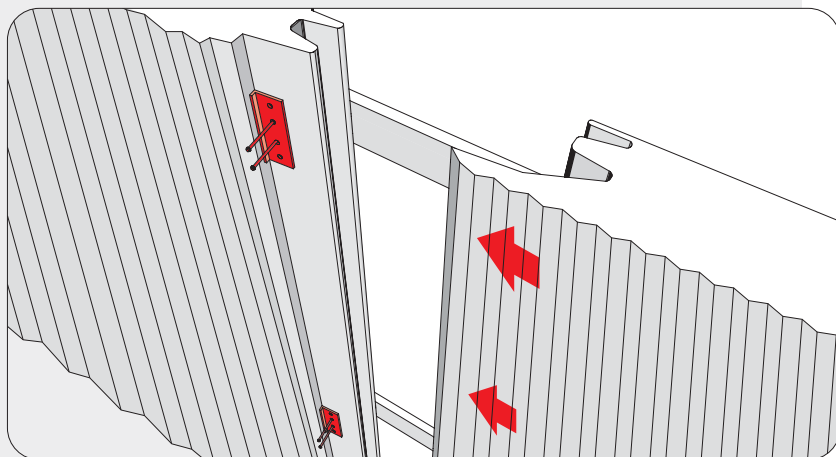

The installation of all panels with a concealed joint from the Europanels range requires the use of a special washer—known as a load spreader—and two fasteners at each fixing point. In the case of a vertical layout, the support point consists of a horizontally running purlin, to which the panels are attached. Before fastening the panel, it is essential to remove the protective film; since it covers the entire surface of the panel—including the interlocking joint—removing it later would be impossible.

Once the first panel has been leveled, the designated fixing point is the panel's specially profiled edge, where the load spreader is to be positioned. Next, secure the panel to the purlin—passing through the load spreader—using appropriate self-drilling screws from the Europanels range. The subsequent panel overlaps the joint using a tongue-and-groove mechanism; therefore, ensure it is pressed firmly into place to achieve a complete connection, and then secure it on the opposite side using a load spreader and screws, as described above.

2.2. Panel Mounting with Concealed Joints – Horizontal Layout (PolTherma DS and PS)

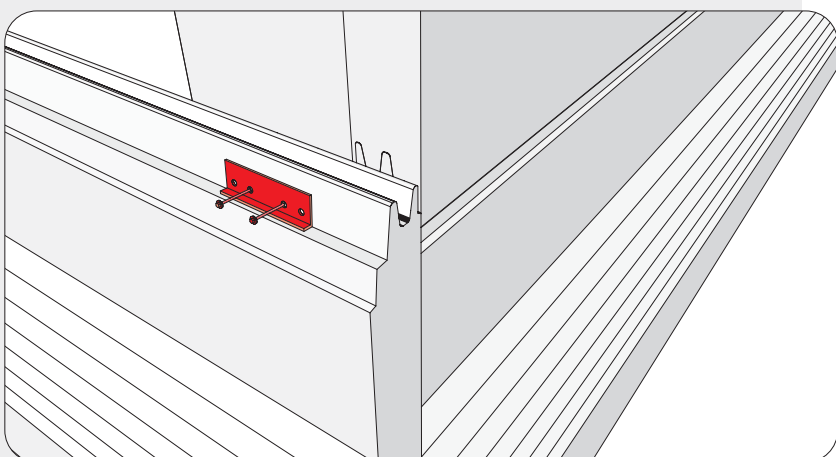

For the installation of all sandwich panels in the PolTherma DS series—regardless of their thickness or profiling—it is essential to use a special load-distributing washer, known as a load distributor. The distributor takes the form of an angle bracket featuring holes that allow the screw spacing to be adjusted to suit various supporting profiles. Each load distributor requires the use of two (2) mounting screws. Prior to fastening the panel, it is necessary to remove the protective film; as this film covers the entire surface of the panel—including the interlocking joint—removing it at a later stage would be impossible.

The assembly comprising the load distributor and mounting screws is positioned within a specially profiled section of the panel's interlocking joint. As a result, the heads of the screws remain invisible from the exterior.

2.3. Installation of the next slab

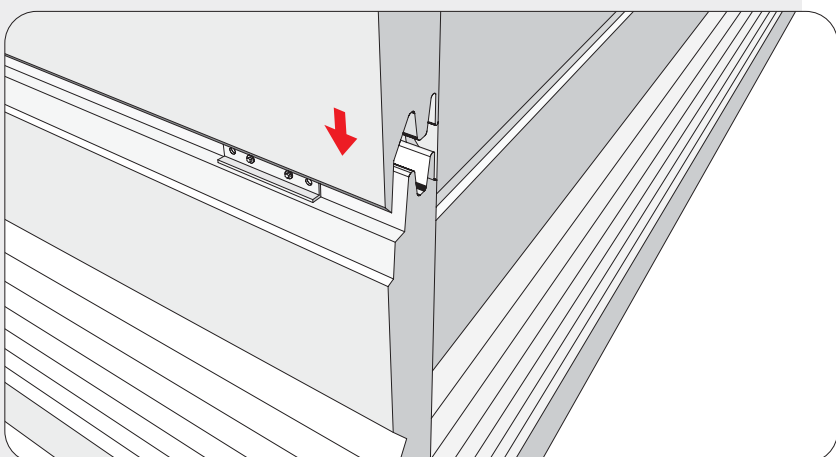

Installing the first panel is crucial, as it establishes the alignment for the subsequent panels, which—in a horizontal configuration—rest one upon the other.

Once the first panel has been leveled and secured, the next panel engages with it via a tongue-and-groove joint, with its "nose" section concealing the interlocking mechanism and fasteners.

Ensure that the panel rests with its full weight upon the preceding one, then secure it by repeating the procedure from the previous stage.

3. INSTALLATION OF THE NEW GENERATION 046 CORNER FLASHING

The new generation of Europanel's corner trims with concealed fastening has been developed primarily for the aesthetic finishing of building corners constructed from sandwich panels installed in a horizontal configuration.

3.1. Auxiliary Handles (Base) 047

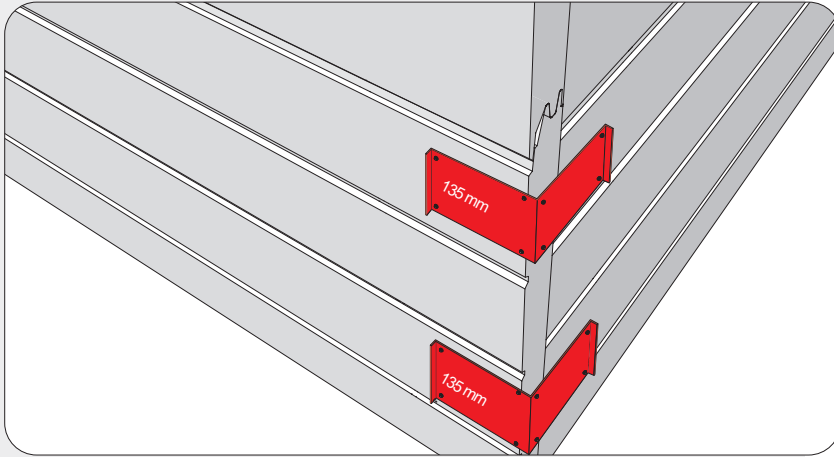

Once the sandwich panels have been fixed to the structure, the installation of the corner flashings begins by positioning, leveling, and fastening the auxiliary brackets (Type 047) to the panel cladding.

The brackets have one fixed dimension (135 mm) and one variable dimension depending on the wall panel thickness. If the panels meet flush at the corner (without a 45° miter), the fixed leg of the bracket should be placed against the continuous panel, while the variable leg should extend beyond the panel joint.

Each 2.5 m section of external flashing (Type 046) requires four auxiliary brackets (Type 047): one at each end and two spaced approximately 1 m apart. The end brackets should remain visible after installation. Only the first flashing section should align flush with the bottom bracket edge, and the last section with the top edge.

The brackets are fixed to the panel cladding using sheet metal screws or self-drilling fasteners. Each bracket requires four fasteners positioned about 25 mm from the bracket edges.

3.2. Installation of Corner Angle 046

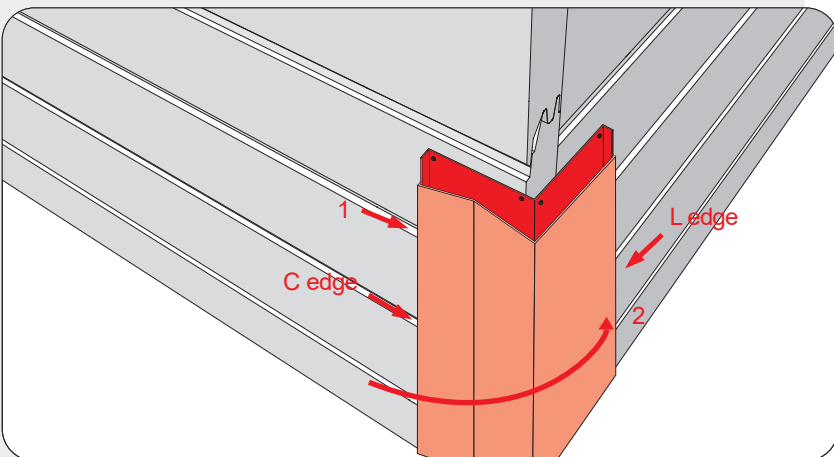

Once the mounting brackets have been prepared in this manner, you may proceed with the installation of the 046 external corner trim. One edge of the trim (the profiled edge) is bent into a "C" shape, while the other (the variable, non-profiled edge) is bent into an "L" shape. First, insert the "C" edge into the gap between the sandwich panel cladding and the auxiliary bracket (Step 1); then, position the trim such that, on the opposite side, a clearance of approximately 1 mm is maintained between the trim edge and the panel cladding (Step 2).

During the installation of the trim, particular attention should be paid to the sharp "L" edge. Exercising caution will help prevent potential bodily injury as well as scratching of the sandwich panel cladding.

3.3. Final Assembly

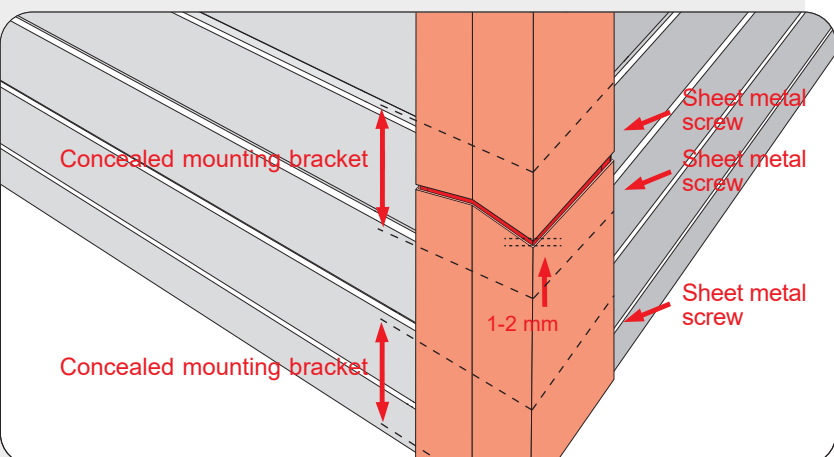

Flasings of this type are not designed for longitudinal lap joints (i.e., they do not overlap). For this reason, they are symmetrical, and a gap of approximately 2 mm should be maintained at their longitudinal joints.

Flashing 046 is secured on the "L" side to the profiled element of brackets 047 using mini-sheet metal screws or sealed steel rivets at four points—specifically, one screw per auxiliary bracket corresponding to the given flashing.

During installation, care must be taken to avoid scratching the facing of the sandwich panel while drilling or driving the screws.

PolTherma TS



PolTherma TS

PolTherma TS is a wall sandwich panel featuring a rigid polyurethane foam (PU) core, secured to the supporting structure using a fastener that passes through the entire thickness of the panel (through-fix). Its key advantages include ease of installation, a highly favorable effective coverage width (1130 mm), and the use of a specialized seal at the joint to enhance connection tightness.

PolTherma TS panels can be installed in both horizontal and vertical orientations on various supporting structures: steel, timber, or reinforced concrete.

Panel cross-section

1130 mm



Available panel thicknesses [mm]

40	60	80	100	120	160	200
----	----	----	-----	-----	-----	-----

Thermal conductivity coefficient λ_D [W/(m·K)]

0.022

Heat transfer coefficient U_d, S for profiling M, R and L [W/(m²·K)]

0.62	0.39	0.29	0.23	0.18	0.14	0.11
------	------	------	------	------	------	------

Heat transfer coefficient U_d, S for profiling MK550 [W/(m²·K)]

0.75	0.44	0.31	0.24	0.20	0.15	0.12
------	------	------	------	------	------	------

Mass 1 m² [kg]

9.5	10.3	11.0	11.8	12.6	14.1	15.6
-----	------	------	------	------	------	------

Maximum number of discs per pack [pcs]

28	18	14	11	9	7	5-6
----	----	----	----	---	---	-----

Cross-section of the joint between plates with thicknesses of 40–80 mm:

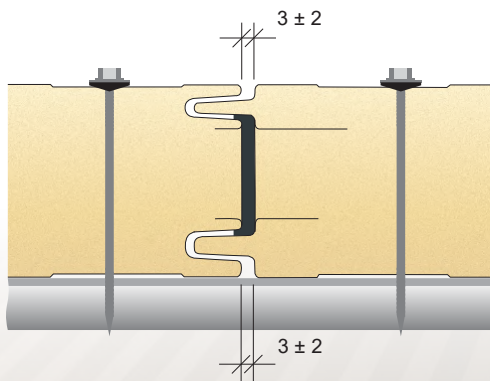

Cross-section of the joint between plates with thicknesses of 100–200 mm:

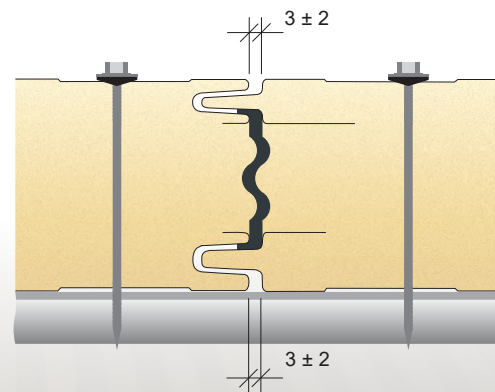

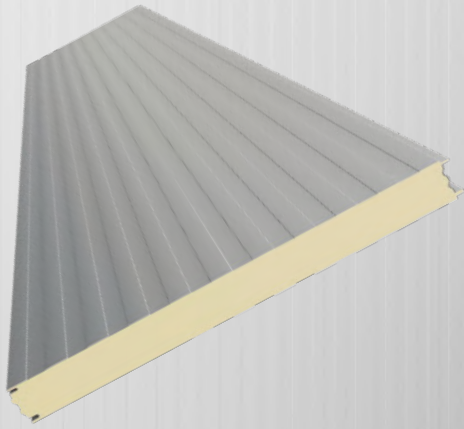

Single module

Linear
L

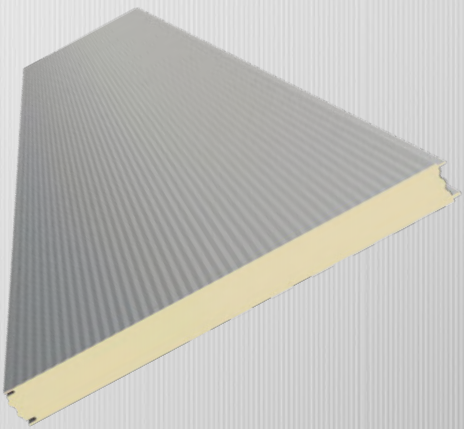

Single module

Microprofiling
M

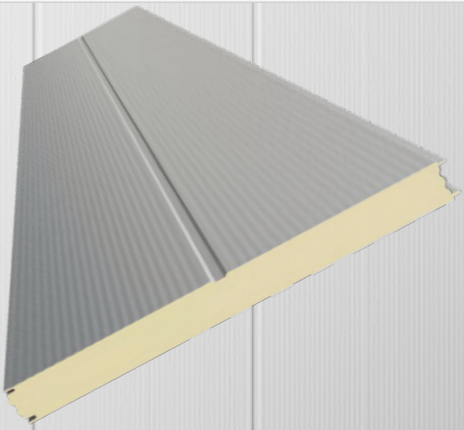

Single module

Micro-cassette
MK550

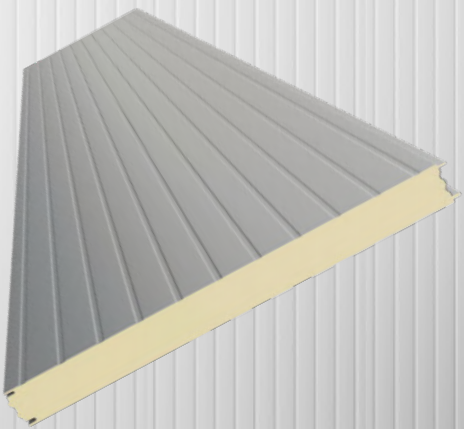

Single module

Grooved
R

PolTherma TS X

PolTherma TS X is a wall sandwich panel featuring a rigid polyurethane (PU) foam core, secured to the supporting structure using a fastener that passes through the entire thickness of the panel (through-fix). Its key advantages include ease of installation, a highly favorable effective coverage width, and the use of a specialized seal at the joint, which enhances connection airtightness.

PolTherma TS X panels can be installed in both horizontal and vertical orientations on various supporting structures—including steel, timber, and reinforced concrete.

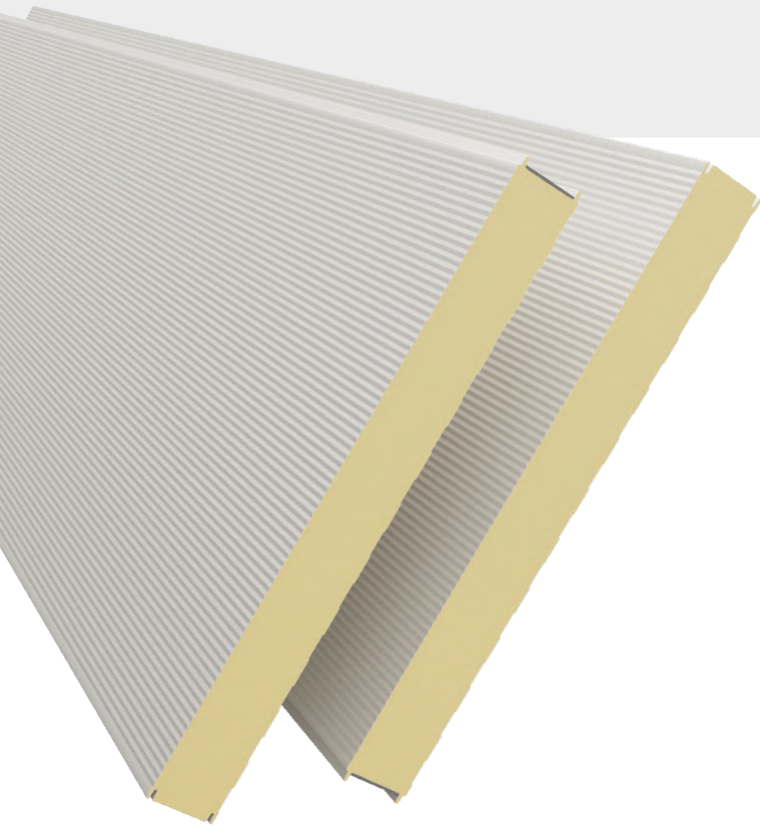

Available panel thicknesses [mm]

40	60	80	100	120	140	160	180	200
----	----	----	-----	-----	-----	-----	-----	-----

Thermal conductivity coefficient λD [W/(m·K)]

0.022

Heat transfer coefficient U_d, S for profiling L, M, SM [W/(m²·K)]

0.50	0.35	0.26	0.21	0.18	0.15	0.13	0.12	0.11
------	------	------	------	------	------	------	------	------

Mass 1 m² [kg]

9.5	10.3	11.0	11.8	12.6	13.3	14.1	14.8	15.6
-----	------	------	------	------	------	------	------	------

Maximum number of discs per pack [pcs]

28	18	14	11-12	9	8	7	6	5-6
----	----	----	-------	---	---	---	---	-----

Modular widths

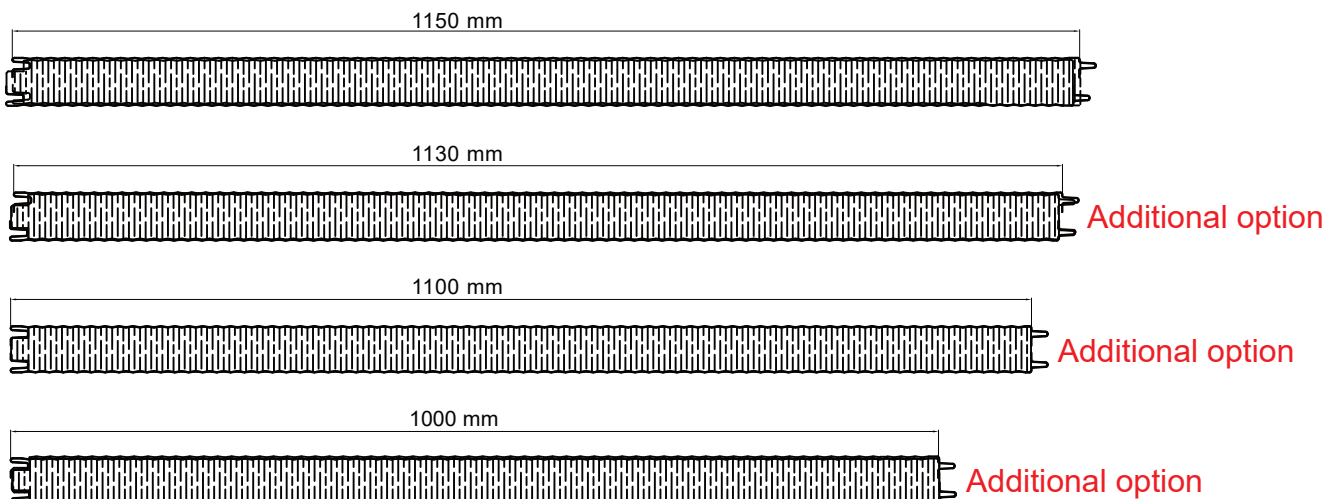

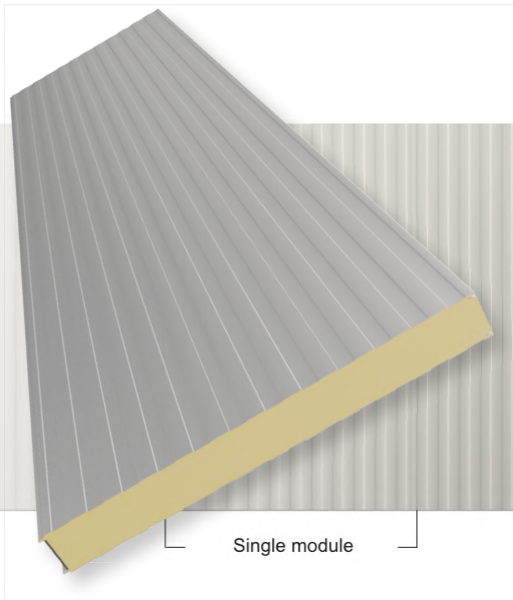

Linear
L

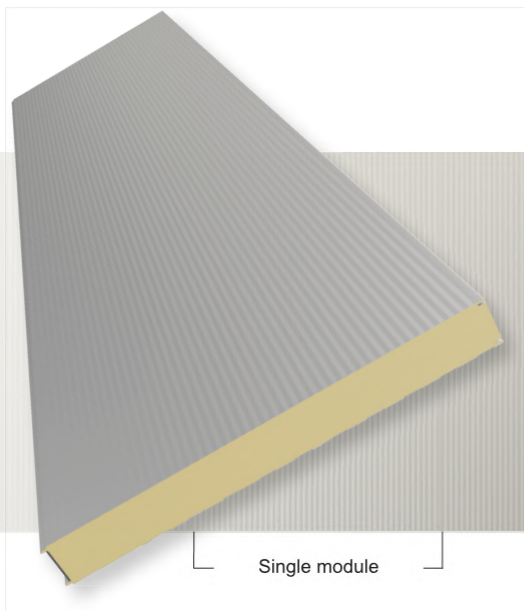

Microprofiling
M

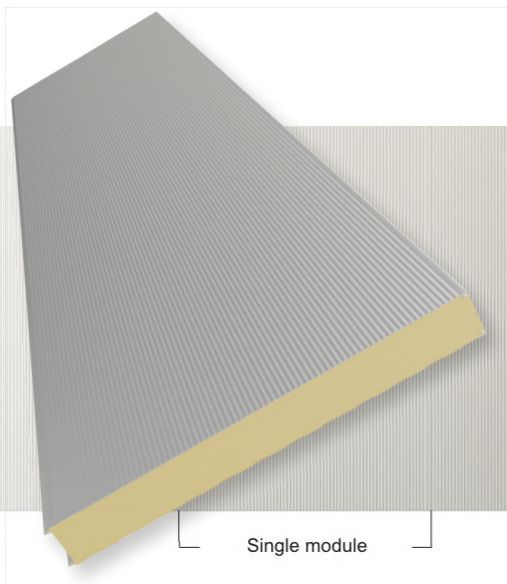

Super-Micro
SM

1. INSTALLATION OF WALL PANELS ON A SILL PLATE

1.1. Mounting of the Starter Workpiece – 013

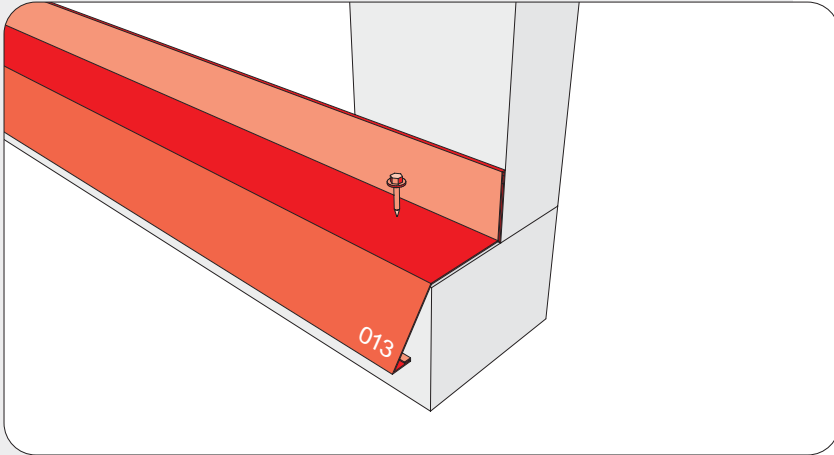

In a traditional structural design—where a sill beam is situated between the columns—this beam serves as the base for mounting sandwich wall panels, which may be installed in either a vertical or horizontal orientation.

First, verify that the surface of the beam is flat along its entire length. Typically, due to the length of the sill beam, it is necessary to level the surface by filling any irregularities—for instance, using a frost-resistant adhesive compound.

If the surface of the sill beam is even, place the 013 masking strip onto it. Next, secure the strip to the sill beam using appropriate screws from the Europanels product range.

1.2. Placing the First Plate

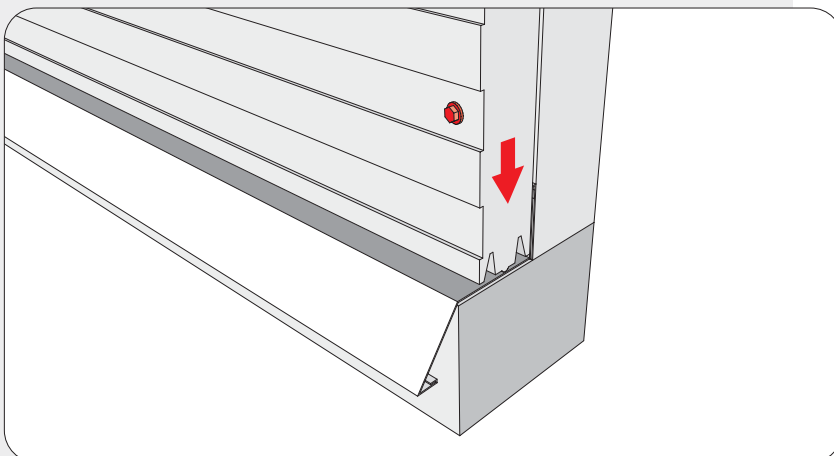

Install the first wall panel on the prepared substrate. The entire weight of the panel should rest evenly on the sole plate. It is crucial to level the first panel, as any deviation from true vertical or horizontal alignment will only be amplified and accentuated by subsequent panels.

Secure the panel to the structure using self-drilling screws from the Europanels range, selected to match the specific thickness of the panel and the structural framing. Each screw should be positioned approximately 40–50 mm from the edge of the panel.

Before installing the panel, ensure that acoustic tape from the Europanels range has been applied to the studs or girts.

1.3. Final Assembly of Strip 013

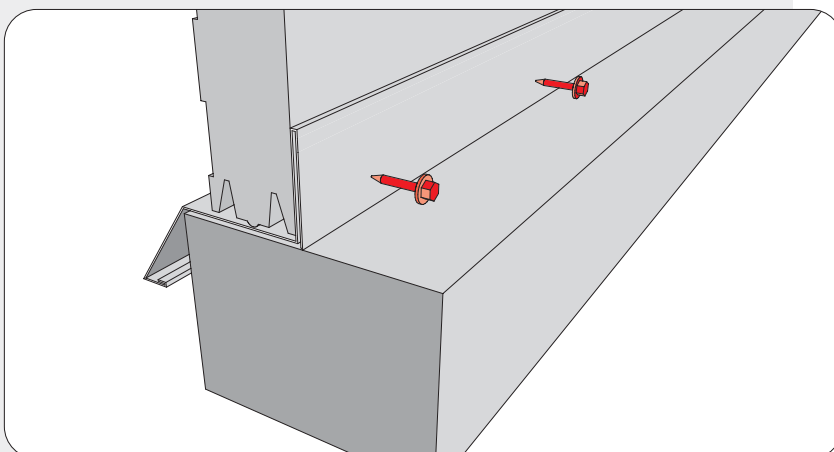

After securing the panel to the structure from the interior of the building, fasten trim 013 using screws from the Europanels product range.

The recommended spacing for fastening points is 300 mm.

Advice: When fastening screws, use a screwdriver equipped with a torque clutch. This will help you avoid applying excessive force, which causes the adverse "cupping" effect.

2. INSTALLATION OF THE NEW GENERATION 044 CONCEALING TRIM

The new generation of Europanels trim with concealed fastening is designed to provide an aesthetic and modern finish to the longitudinal joints of wall sandwich panels mounted to structural columns in a single-span horizontal configuration. The primary advantage of these trims is the absence of visible fastening elements, which harmonizes perfectly—particularly with the PolTherma DS series of decorative wall panels.

2.1. Auxiliary Mounts (Bases) 045

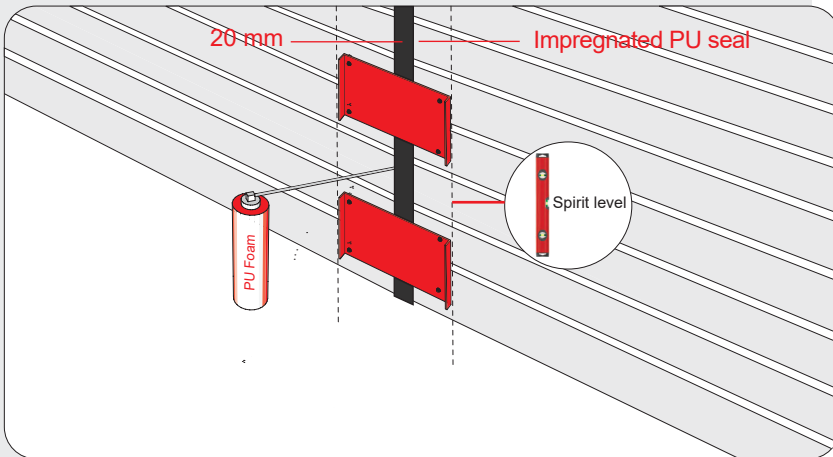

After securing the panels to the posts (maintaining a 20 mm expansion gap—filled with low-expansion mounting foam and subsequently covered with a strip of self-adhesive, impregnated PU foam—is required), the 045 auxiliary brackets (bases) must be positioned, leveled, and screwed to the panel cladding.

Four brackets are required for each 2.5 m length of flashing. Bracket spacing: one bracket at each end of the flashing, with the remaining brackets spaced approximately 1 m apart.

In the case of end brackets, they must remain visible after the flashing has been installed. Only the bottom starter flashing and the top finishing flashing may cover the brackets.

The auxiliary brackets are fastened to the cladding using sheet metal screws or self-drilling screws. Each bracket requires four fasteners, positioned at the corners approximately 25 mm from the bracket's edges.

2.2. 044 Masking Strip Processing Unit

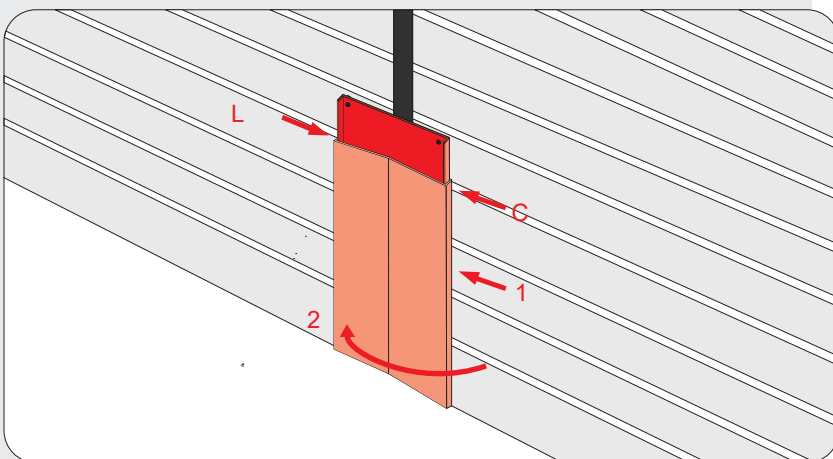

Once the mounting brackets have been prepared in this manner, you may proceed with the installation of the 044 trim strip. One edge of the flashing is bent into a "C" shape, and the other into an "L" shape. First, insert the "C" edge into the gap between the sandwich panel cladding and the auxiliary bracket (Step 1); then, position the flashing so that, on the opposite side, a gap of approximately 1 mm is maintained between the edge of the flashing and the panel cladding (Step 2).

During the installation of the flashing, particular attention should be paid to the sharp "L" edge. Exercising caution will help prevent potential bodily injury as well as scratching of the sandwich panel cladding.

2.3. Final Assembly

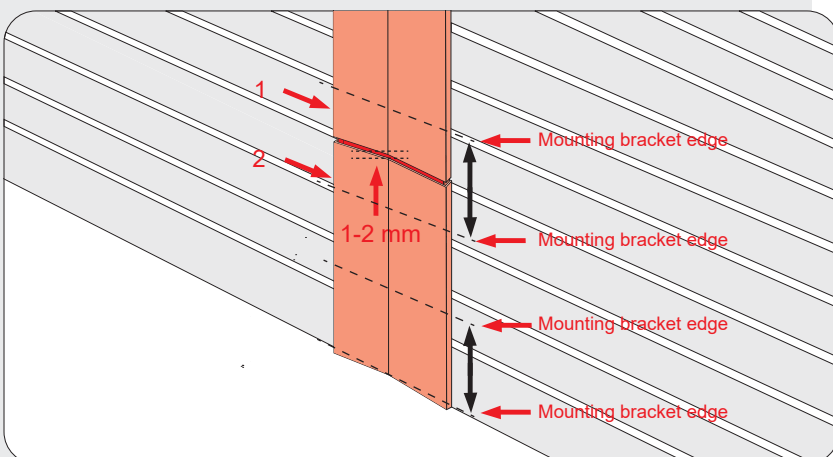

Fittings of this type are not designed for longitudinal lap joints (i.e., they do not overlap). For this reason, they are symmetrical, and a gap of approximately 2 mm should be maintained at the point of their longitudinal connection.

Fitting 044 is secured on the "L" side to the profiled base element 045 using mini-sheet metal screws or sealed steel rivets at four points—specifically, one screw per auxiliary bracket.

During installation, care must be taken to avoid scratching the facing of the sandwich panel while drilling or driving screws.

PolTherma CS





PolTherma CS

PolTherma CS is a specialized sandwich panel featuring a rigid polyurethane foam (PU) core, designed for refrigeration applications. It is fastened to the supporting structure using a connector (stainless steel is recommended) that passes through the entire thickness of the panel. Beyond refrigeration contexts, this panel is an ideal choice wherever high thermal insulation performance for walls is a priority.

The PolTherma CS panel is particularly recommended for the food processing and agricultural construction sectors, serving as a wall structure or as a suspended ceiling system—for instance, in fruit and vegetable storage facilities, deep freezers, cold stores, meat processing plants, or slaughterhouses.

For facilities operating at very low temperatures, 100% insulation tightness is ensured by a polyurethane-injected joint applied on-site. This solution yields tangible cost savings through reduced electricity consumption.

Panel cross-section

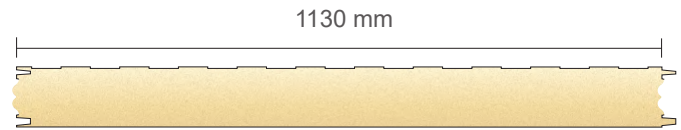

Available panel thicknesses [mm]

120	160	200
-----	-----	-----

Thermal conductivity coefficient λD [W/(m·K)]

0.022

Heat transfer coefficient U_d, S for profiling M, R and L [W/(m²·K)]

0.18	0.14	0.11
------	------	------

Heat transfer coefficient U_d, S for profiling MK550 [W/(m²·K)]

0.20	0.15	0.12
------	------	------

Mass 1 m² [kg]

13.4	14.9	16.5
------	------	------

Maximum number of discs per pack [pcs]

9	7	5-6
---	---	-----

Plate joint cross-section – standard

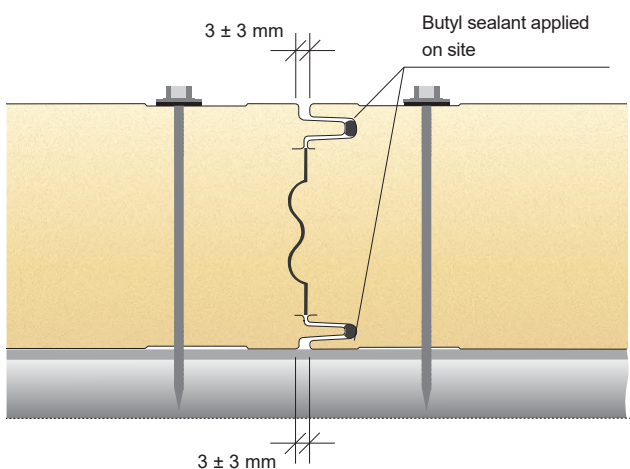

Panel joint cross-section – sealed joint

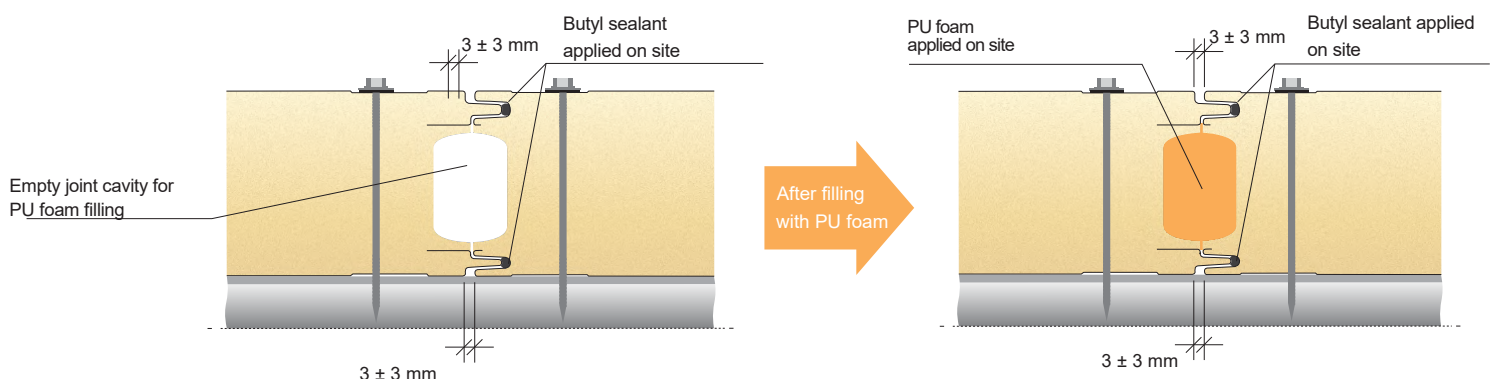

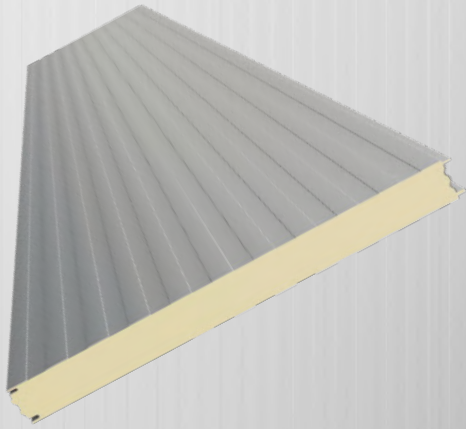

Single module

Linear
L

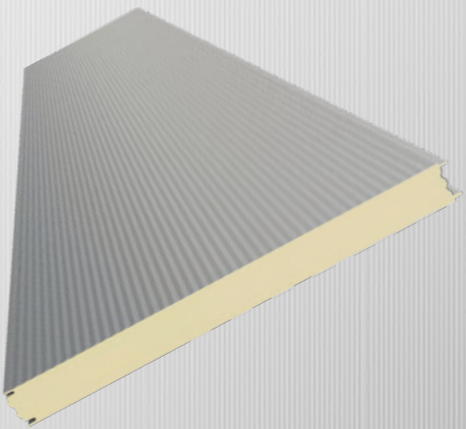

Single module

Microprofiling
M

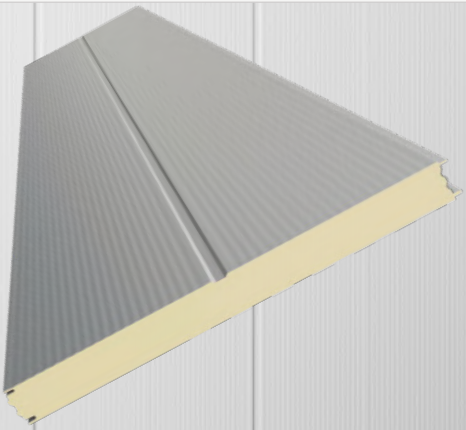

Single module

Micro-cassette
MK550

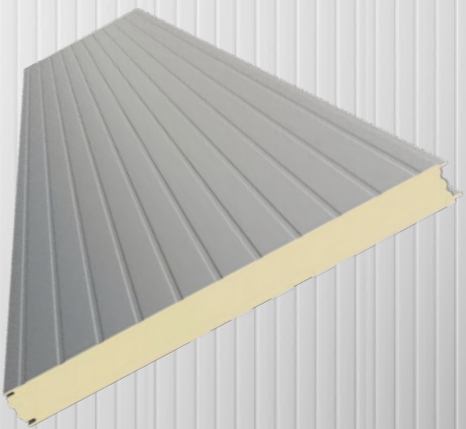

Single module

Grooved
R

PolTherma CS X

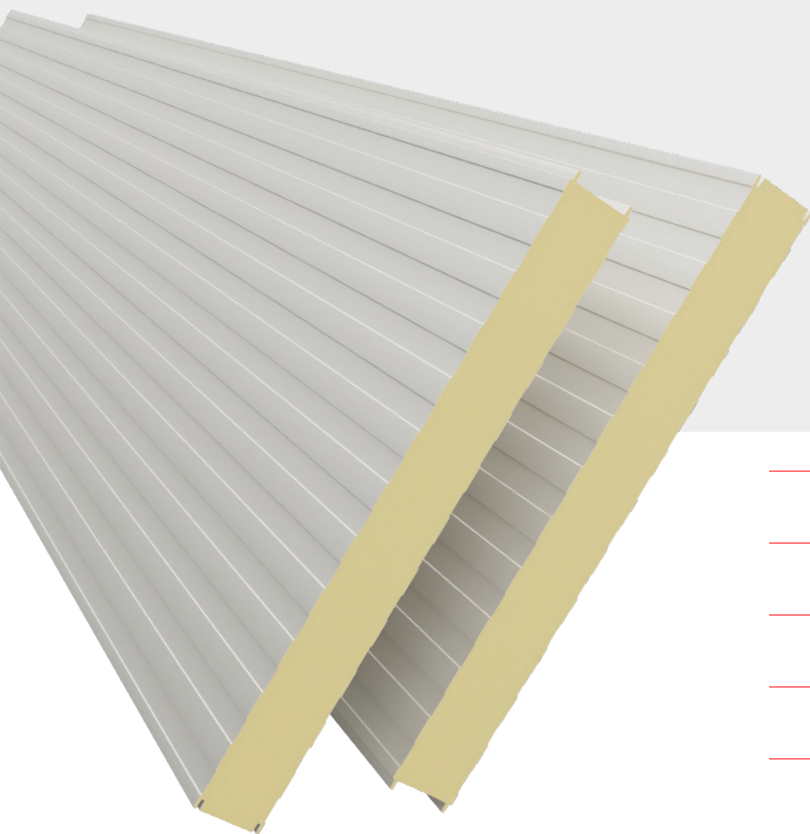

PolTherma CS X is a specialized sandwich panel featuring a rigid polyurethane (PU) foam core designed for refrigeration applications. It is fastened to the supporting structure using a fastener (stainless steel recommended) that passes through the entire thickness of the panel. Beyond refrigeration applications, this panel is an ideal choice wherever high thermal insulation performance for walls is a priority.

The PolTherma CS X panel is particularly recommended for the food industry and agricultural construction, serving as a wall structure or a suspended ceiling system—for instance, in fruit and vegetable storage facilities, deep freezers, cold stores, meat processing plants, or slaughterhouses.

For facilities operating at very low temperatures, 100% insulation airtightness is ensured by a polyurethane-injected joint applied on-site. This allows for tangible cost savings resulting from reduced electricity consumption.

Available panel thicknesses [mm]

120	140	160	180	200
-----	-----	-----	-----	-----

Thermal conductivity coefficient λ_D [W/(m·K)]

0.022

Heat transfer coefficient U_d, S for profiling L, M, SM [W/(m²·K)]

0.18	0.15	0.13	0.12	0.11
------	------	------	------	------

Mass 1 m² [kg]

12.6	13.3	14.1	14.8	15.6
------	------	------	------	------

Maximum number of discs per pack [pcs]

9	8	7	6	5-6
---	---	---	---	-----

Modular widths

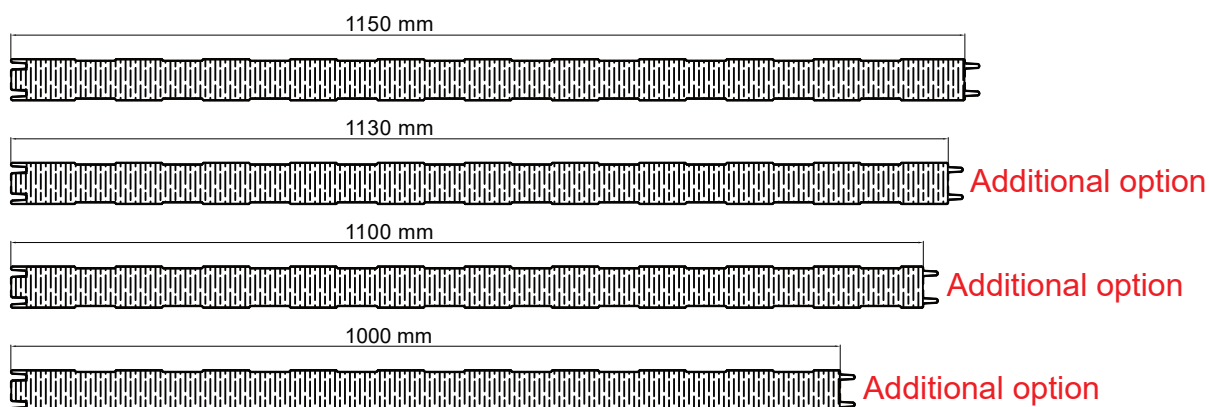

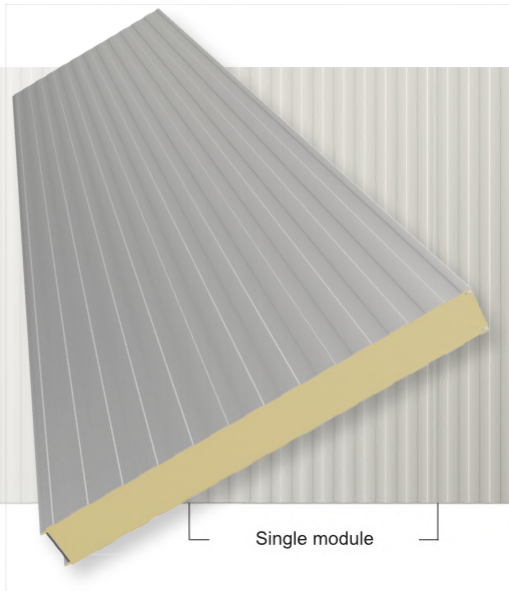

Linear
L

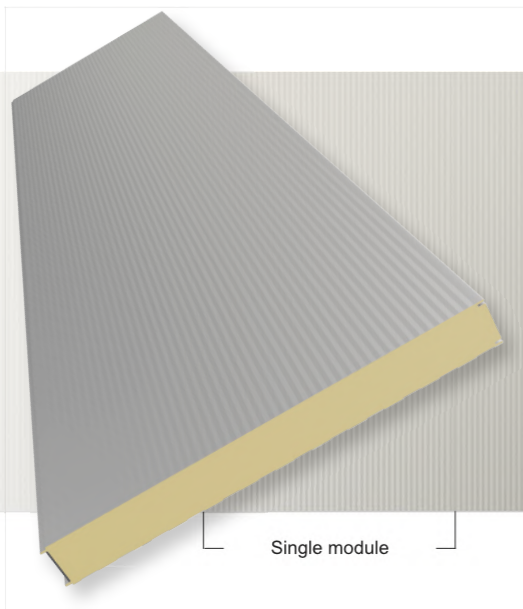

Microprofiling
M

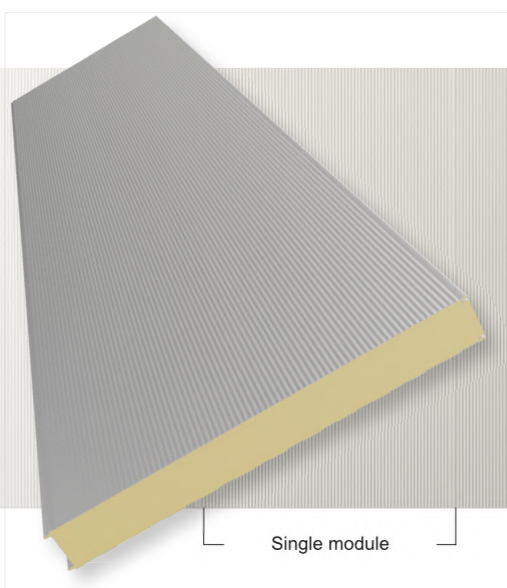

Super-Micro
SM

PolDeck TD

Before ordering PolDeck TD panels

It is important to accurately measure panel lengths before ordering to avoid waste or installation issues. Lengths should be defined in the design documentation or measured on the completed roof structure. The Ordering Party is responsible for these measurements.

Panel thickness should be selected based on building use and insulation requirements. For occupied buildings, roof panels typically require a heat transfer coefficient not exceeding $0.15 \text{ W/m}^2\cdot\text{K}$. PolDeck TD 145/180 and 165/200 panels meet this requirement.

The roof support structure (steel, timber, or reinforced concrete) must comply with design specifications. Appropriate Europanels fasteners are used depending on the material. Purlin spacing, profile, and dimensions must strictly follow the design, as the structure transfers snow, wind, and rain loads from the panels.

Due to solar heating, white roof panels (e.g. RAL 9010) are recommended. Expansion joints and longitudinal splicing are also advised to allow thermal movement and reduce stress in the roofing system.





PolDeck TD

PolDeck TD is a roofing sandwich panel featuring a rigid polyurethane (PU) foam core, secured to the supporting structure using a fastener that passes through the entire thickness of the panel. PolDeck TD is a versatile panel suitable for a wide variety of building types, with roof slopes of at least 4° (7%) for continuous panels, and 6° (10%) for panels joined longitudinally, those incorporating skylights, etc.

Roof panel cutouts – available options:

- Left cutout 150–300 mm: thicknesses 40, 60, 80
- Left cutout 50–300 mm: thicknesses 100, 120, 145, 165
- Right cutout 50–300 mm: thicknesses 100, 120, 145, 165

Plate joint cross-section

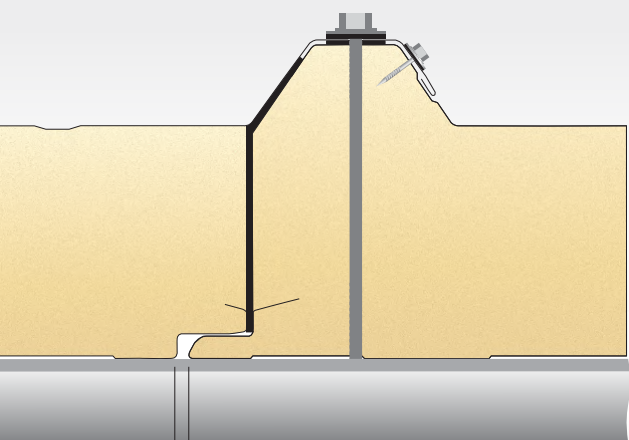

3 ± 2 mm

Panel cross-section

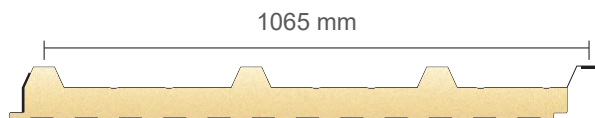

Available panel thicknesses [mm]

40/75	60/95	80/115	100/135	120/155	145/180	165/200
-------	-------	--------	---------	---------	---------	---------

Thermal conductivity coefficient λD [W/(m·K)]

0.022

Heat transfer coefficient U_d, S [W/(m²·K)]

0.56	0.37	0.28	0.22	0.19	0.15	0.13
------	------	------	------	------	------	------

Mass 1 m² [kg]

10.7	11.5	12.3	13.0	13.8	14.8	15.6
------	------	------	------	------	------	------

Maximum number of discs per pack [pcs]

18	14	10	8	8	6	5-6
----	----	----	---	---	---	-----

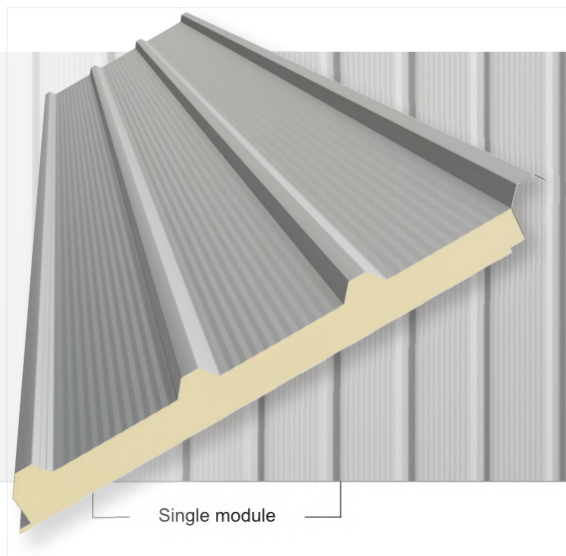

Micro-Trapezoidal
TM

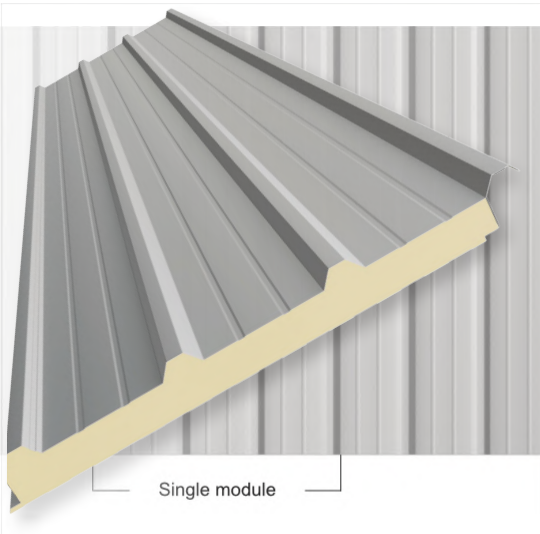

Trapezoidal
T

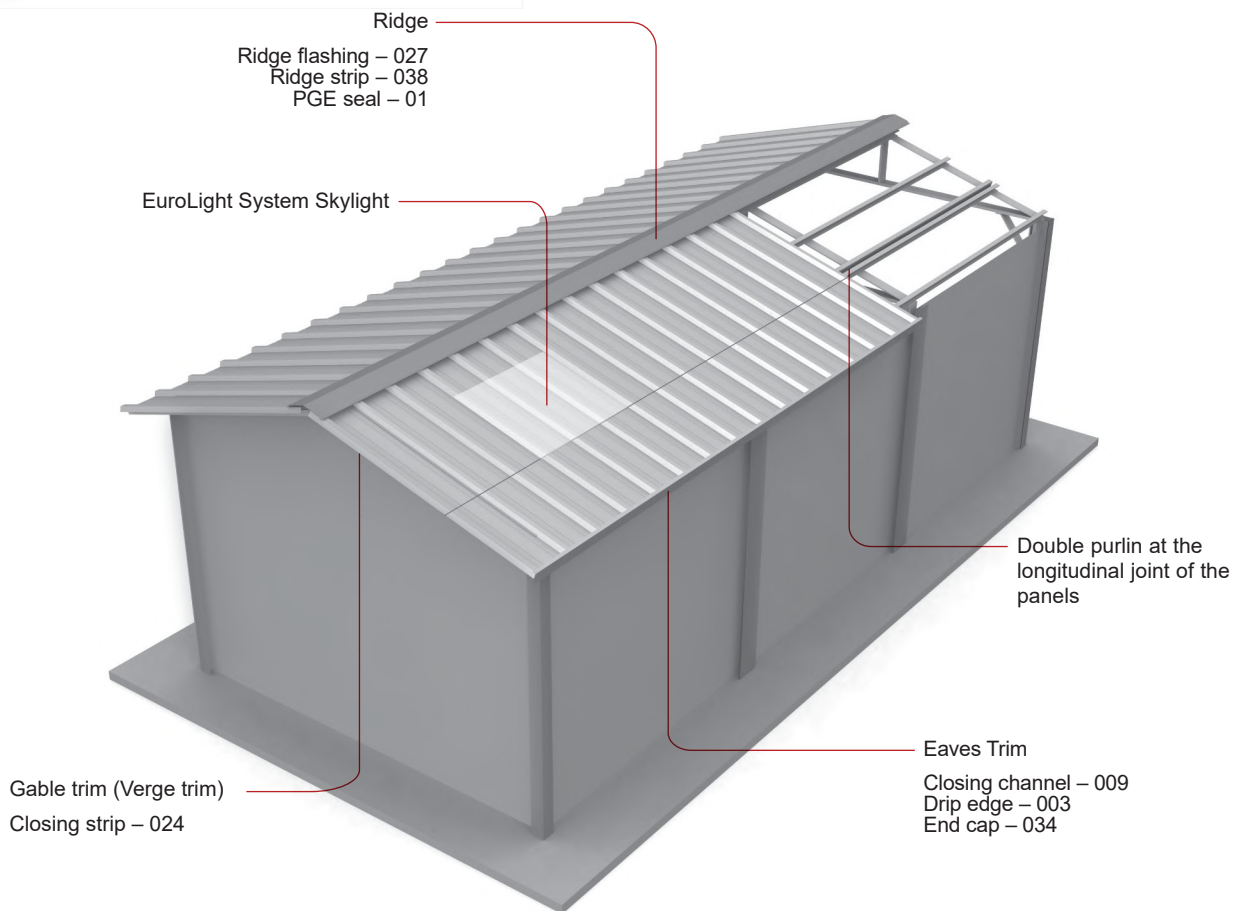

1. INSTALLATION OF PANELS ON STEEL STRUCTURES

1.1. Removing the protective film

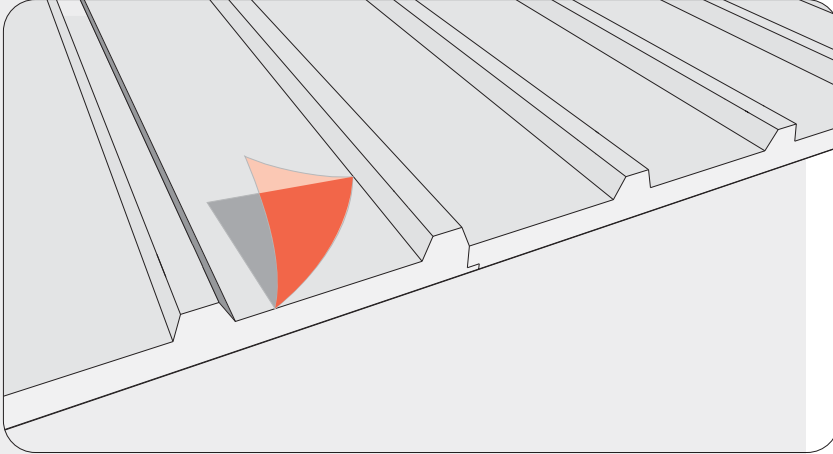

The protective film is designed to shield the panel surface against mechanical damage during transport. However, its presence is not intended during the panel's operational lifecycle. Leaving the film on the cladding surface will result in its vulcanization under the influence of sunlight. This may lead to the voiding of the panel warranty; therefore, the protective film must be removed as soon as possible (no later than one month from the date of the panels' manufacture).



Advice: Beware of metal shavings that may appear during panel installation as a result of drilling and cutting. All shavings must be thoroughly removed, as they act as potential sources of corrosion! When removing them, avoid mechanically rubbing the shavings against the cladding surface. We recommend washing the roof with a strong stream of water.

1.2. Installation of acoustic insulation on purlins

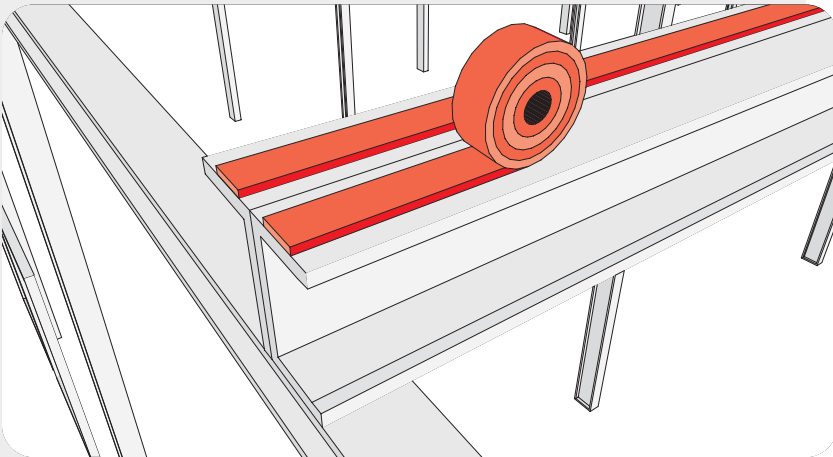

Adhere an acoustic tape from the Europanel's product range to the surface of the purlin that is in contact with the inner facing of the roof panel. Its specialized properties serve to level the contact plane between the panel and the purlin, while also reducing audible effects resulting from the panel's movement against the supporting structure. Furthermore, this tape prevents scratching of the panels during installation (specifically when sliding them across the structure) and inhibits the transfer of potential corrosion sites from the structure to the panel during the facility's operational lifespan.

1.3. Placement and assembly of plates for the structure

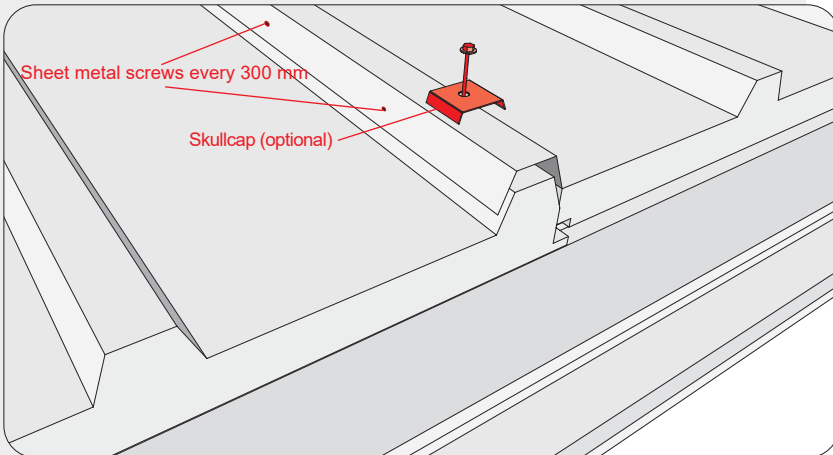

Using appropriate equipment, transport the panel from the storage area to the roof. Position the first panel and fasten it through the rib to the supporting structure using a self-drilling screw from the Europanel's product range. Before drilling, remove the protective film from the fastening point. Next, retrieve the subsequent panel and place it over the previous one. The metal sheet of the overlap rib must fit flush against the surface of the preceding panel along its entire length. The number of fastening points should be specified in the construction design.

Additionally, the metal sheet of the overlap rib is fastened laterally using sheet metal screws spaced every 300 mm. For the installation of PolDeck TD roof panels, we recommend using cap washers, which serve as load-spreading washers to enhance the clamping force of the panels against the supporting structure.



Advice: Self-tapping screws should be driven in when the roof is hottest from the sun's rays.

2. JOINING BOARDS ALONG THEIR LENGTH

2.1. Placement and installation of the first panel

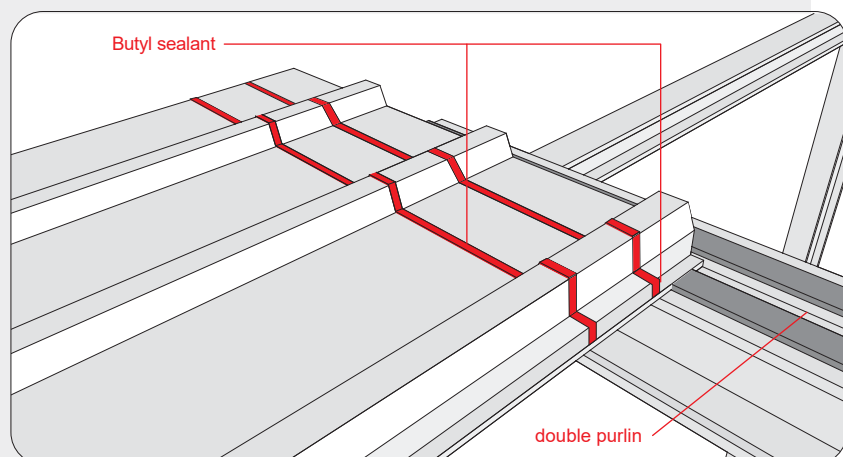

If the roof slope is of considerable length (exceeding 7 m)—due to the significant heat buildup on the cladding surface—the use of single panels spanning the entire length should be avoided. Instead, it is recommended to join several shorter panel sections along the length, incorporating expansion joints. This method is referred to as "underlap" installation.

For this type of installation, double purlins are required at the panel joints. Place the first panel—specifically the one to which the gutter is to be attached—onto this prepared structure. Next, apply butyl sealant across the entire width of the panel, approximately 50 mm from the edge of the end lap, and also apply spot applications at the panel joint, along the edge of the purlin.

2.2. Preparation of the overlap plate

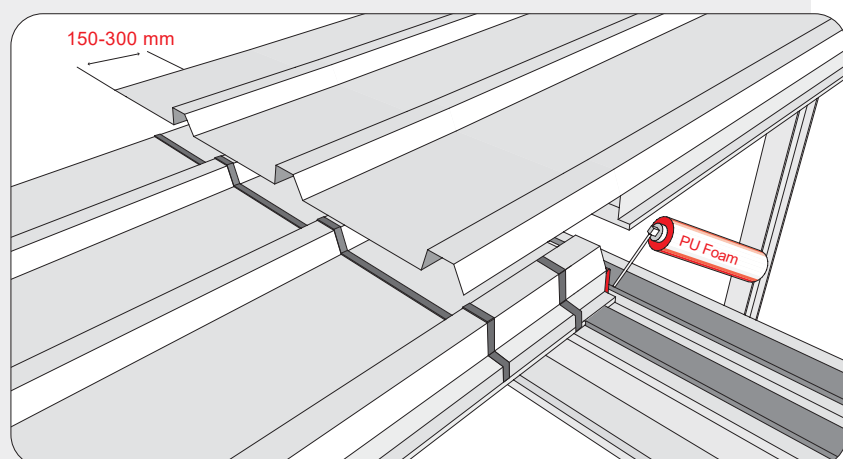

Panels intended for the lap joint—specifically those to be positioned at the ridge—are supplied with a pre-cut recess. This recess involves cutting through the inner facing and the polyurethane core. Prior to installation, the recessed section of the panel must be removed so that only the upper facing remains. The length of the recess ranges from 150 to 300 mm, depending on the roof pitch:

- 150 mm for a pitch above 20%
- 200 mm for a pitch of 16–20%
- 250 mm for a pitch of 11–15%
- 300 mm for a pitch of 7–10%

Before installing the panels, apply a small amount of low-expansion mounting foam to the edge of the first panel.

2.3. Final assembly

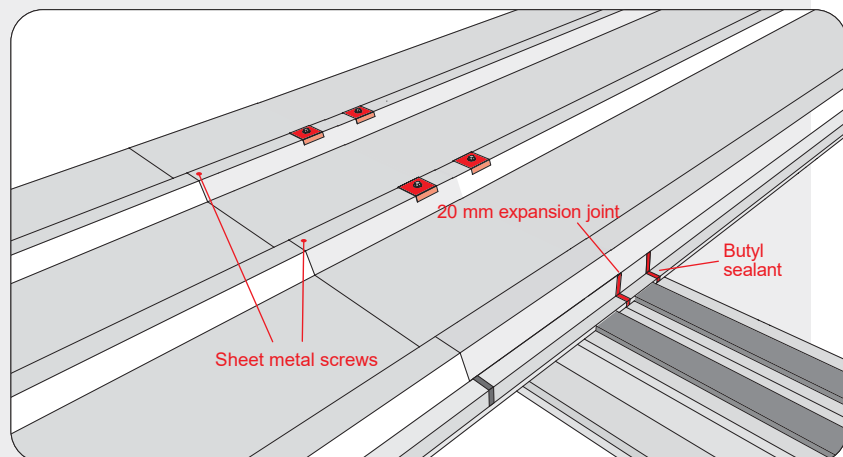

The next step involves overlapping the panels while maintaining a 20 mm expansion gap (a space to be filled with mounting foam). This gap is essential, as it compensates for the thermal movement of the panels on the supporting structure.

Apply butyl sealant to the contact area of the overlapping panel at the edge of the purlin.

Secure the panels using self-drilling screws from the Europanels product range, fastening them to each purlin as appropriate. Additionally, at every rib, insert sheet metal screws at the point where the overlapping sheet makes contact with the butyl sealant (as shown in Fig. 2.1).

Remember that, at this stage of installation, you must not fasten the panel through the rib designated to accommodate the overlap of the subsequent panel.

3. RIDGE INSTALLATION

3.1. Installation of PE-G01 gasket

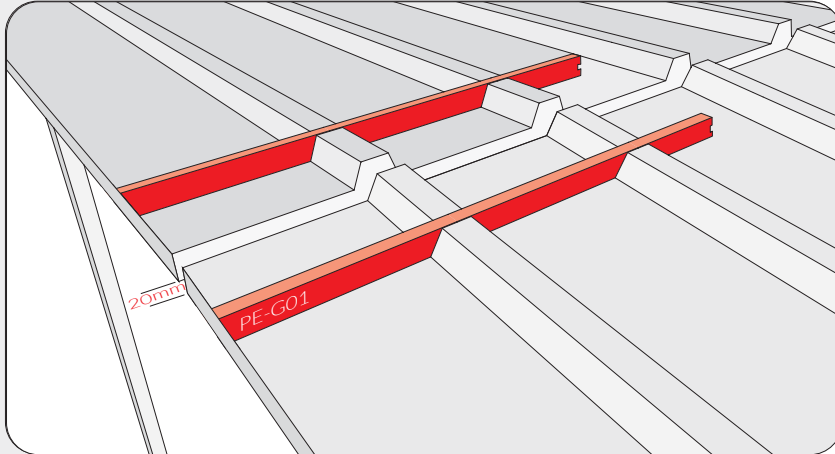

For gable roofs, the panels at the ridge must maintain a clearance of no less than 20 mm from the edge of the interior lining. This is essential to accommodate the panel's movement on the supporting structure (expansion gap). The space between the panels may be filled with polystyrene or polyurethane foam.

Apply the PE-G01 seals to the panels prepared in this manner. One seal is required per roof panel. Repeat this procedure for the panel on the opposing slope.

The positioning of the seals should align with the edge of the ridge flashing.

3.2. Installation of the ridge and inner ridge

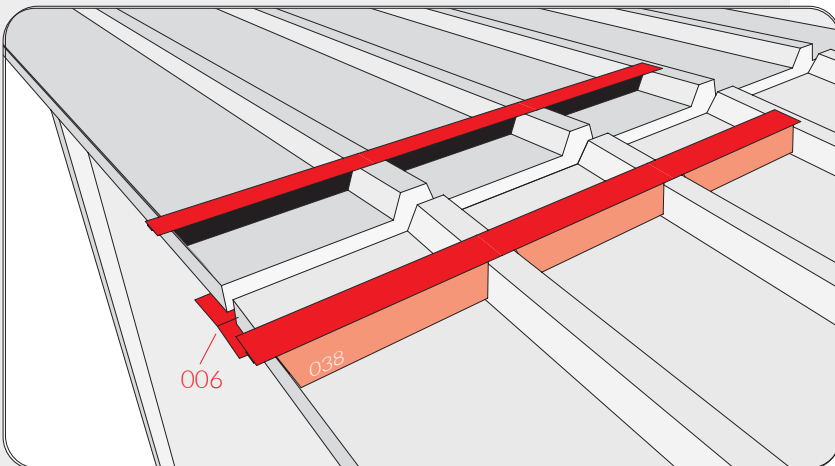

Place the 038 ridge strip (known as a "comb") over the PE-G01 seal. One comb is required per roof panel. The comb covers the seal and levels the surface of the panel ribs, creating a flush plane. Repeat this procedure for the panel on the opposing slope.

The 006 trim piece is used to close off the ridge from the interior; fasten it to the inner liners of the panels using appropriate screws from the Europanel's product range.

3.3. Installation of external ridge 027

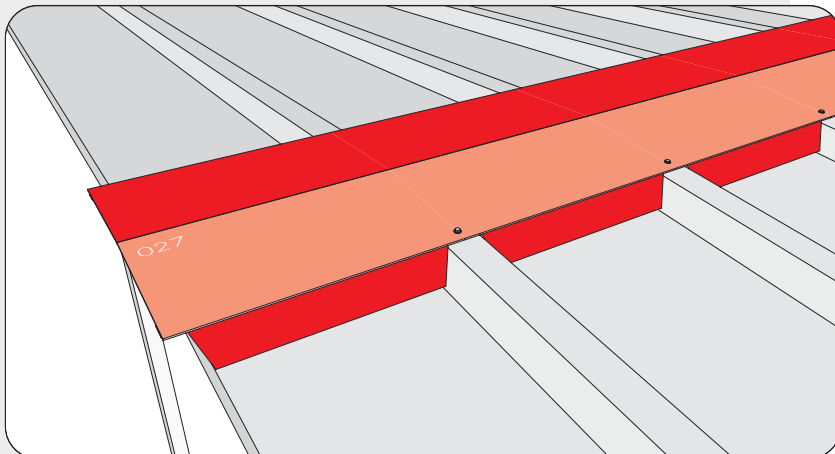

Place the ridge flashing against the crests of the panels and fasten it to each rib using screws from the Europanel's product range. This may be either the 027 external ridge flashing (flat) or the 005 (raised) version.

It is recommended to simultaneously install a number of seal and comb sets corresponding to the length of the external ridge flashing—typically, this amounts to three sets per 2,500 mm length of flashing.

4. INSTALLATION OF THE EAVES FLASHING AND VERGE FLASHING

4.1. Installation of closing channel 009

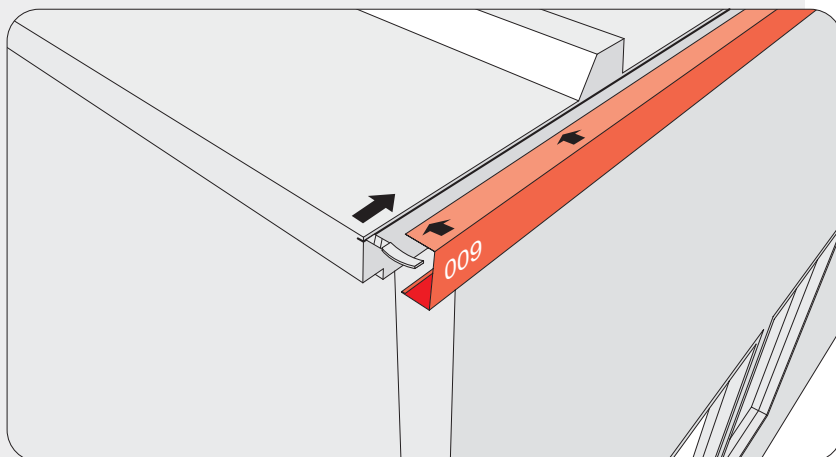

Begin the installation of the gutter apron flashing by making a pilot incision to facilitate the attachment of flashings 009 and 003. Make this incision using a sharp tool positioned just beneath the upper facing, ensuring it is uniform along the entire length of the panel. The incision should have a depth of approximately 40 mm. At locations where gutter brackets are intended to be mounted, it is recommended to bond a 1 mm thick metal strip to the inner surface of flashing 009.

Slide flashing 009 into the slot prepared in this manner. This flashing is manufactured to match the specific thickness of the panel in use; one of its edges features a sharp finish, while the other is curled inward. Insert the flashing into the slot with the sharp edge facing upward. The leading edge of the flashing should rest against the core material. Secure the flashing from the underside at intervals of approximately 300 mm using appropriate screws from the Europanel's product range.

4.2. Installation of drip edge 003 and end cap 034

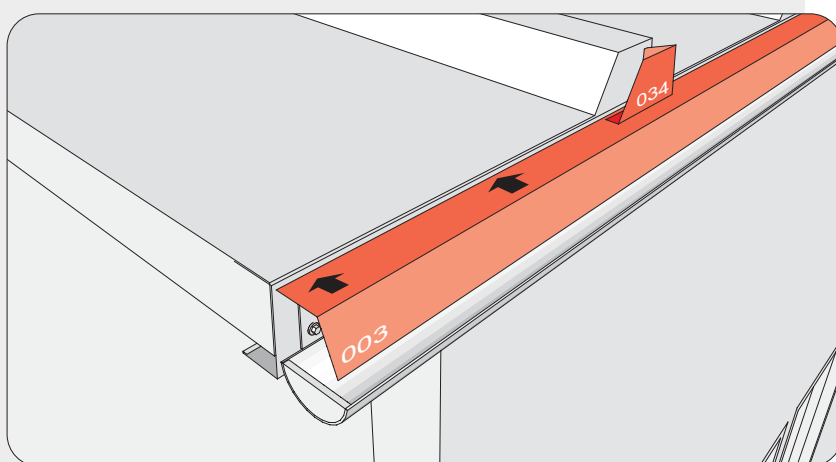

The next step is the installation of drip edge 003. Slide drip edge 003 between the outer facing of the roof panel and the installed flashing 009. Drill through and rivet the entire assembly—i.e., the panel's outer facing, flashing 003, and flashing 009—using two rivets positioned between the ribs. This prepared gutter apron serves as the base for installing the gutter system.

The open polyurethane space within the ribs of the roof panel still remains to be filled. To cap this opening, use masking element 034; slide it beneath the facing of the panel rib and secure it with an appropriate screw from the Europanel's product range.

4.3. Installation of closing strip 024

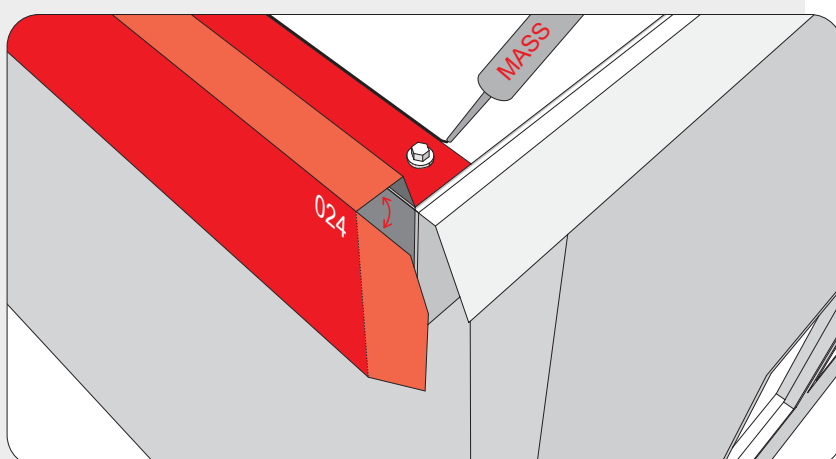

Installation of the 024 gable trim—also known as a wind verge—begins by shortening the overlap flange of the roof panel. It is recommended to shorten this flange at its midpoint (along the embossed feature). Place the 024 trim over the remaining section of the metal sheet. Begin installation at the gutter end, ensuring that subsequent sections of the 024 trim overlap the preceding ones, following the direction of the roof slope. During the initial phase of installation, the 024 trim should extend approximately 70 mm beyond the edge of the gutter apron. Next, trim the upper and lower sections of the 024 trim, leaving the protruding side tab intact; finally, bend this tab inward against the trim to seal the gap.

Secure the entire assembly using appropriate screws and seal it with a specialized sealant from the Europanel's product range.

PolDeck MD

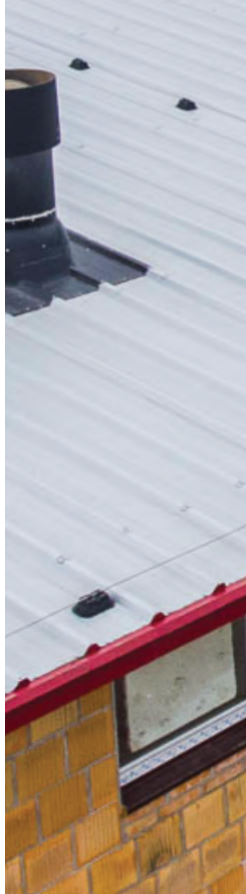
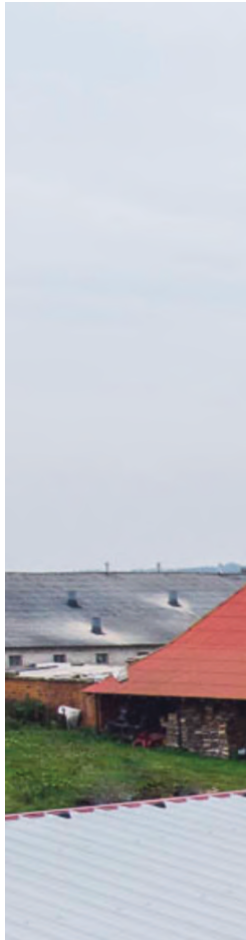



PolDeck MD

PolDeck MD is a roofing sandwich panel featuring a core of rigid polyurethane (PU) foam and an inner facing made of laminated polyester resin—hence the term "laminated"—reinforced with fiberglass. It is fastened to the supporting structure using fasteners that pass through the entire thickness of the panel. The required number of fasteners is determined by load tables and design load calculations.

The outer facing is metal, similar to that found in standard TD roofing panels. The PolDeck MD panel is designed primarily for use in livestock facilities, where elevated concentrations of aggressive substances contribute to a highly corrosive environment.

PolDeck MD panels are suitable for applications in horticulture, storage facilities, warehouses, cattle barns, and poultry houses, as well as in buildings with a minimum roof pitch of 4° (7%) for continuous panels, or 6° (10%) for panels joined lengthwise (e.g., those incorporating skylights). The laminate facings can be cleaned using high-pressure water, provided that appropriate distance and spray direction are maintained.

Plate joint cross-section

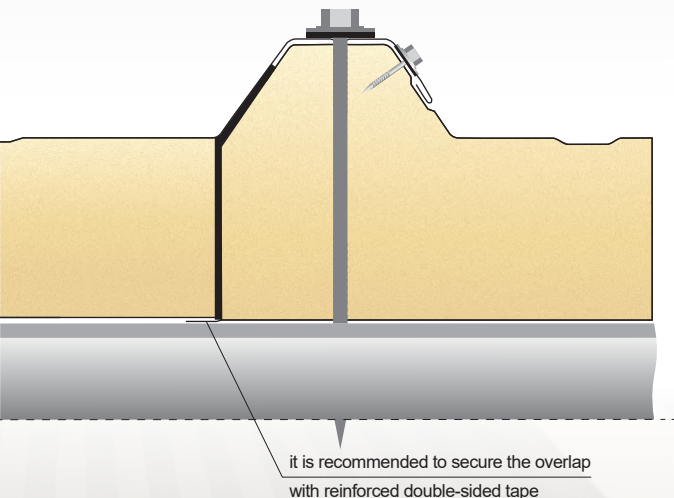

Panel cross-section

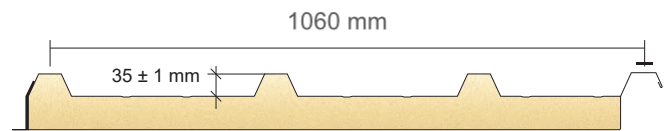

Available panel thicknesses [mm]

40/75	60/95	80/115	100/135	120/155
-------	-------	--------	---------	---------

Thermal conductivity coefficient λD [W/(m·K)]

0.028	0.028	0.027	0.027	0.026
-------	-------	-------	-------	-------

Heat transfer coefficient U_d, S [W/(m²·K)]

0.62	0.43	0.32	0.26	0.22
------	------	------	------	------

Heat transfer coefficient U_d, S for profiling MK550 [W/(m²·K)]

0.75	0.44	0.31	0.24	0.20
------	------	------	------	------

Mass 1 m² [kg]

6.47	7.23	7.98	8.74	9.50
------	------	------	------	------

Maximum number of discs per pack [pcs]

18	14	10	8	8
----	----	----	---	---

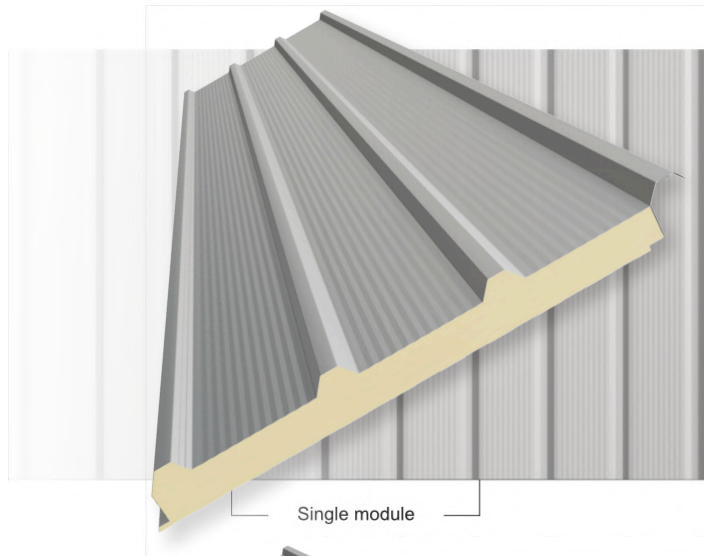

Micro-Trapezoidal
TM

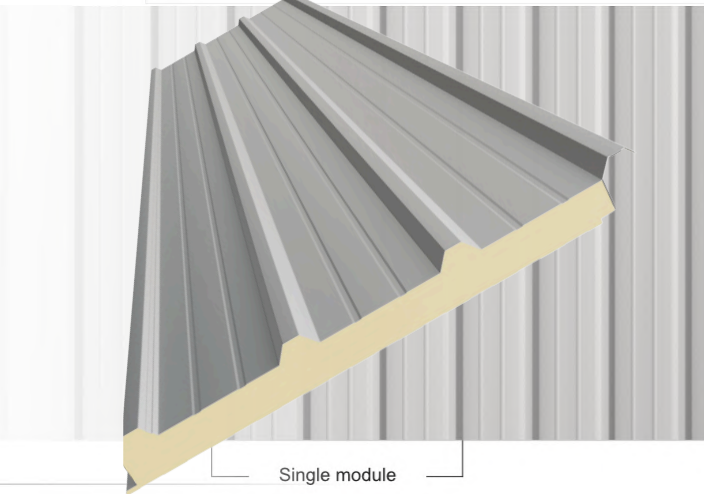

Trapezoidal
T



- Low water absorption – less than 1%
- Resistance to chemicals and biological agents: acids, alcohols, bases, solvents, ammonia, and molds
- The laminate surface can be cleaned using a pressure washer
- Operating temperature range: -40°C to 110°C
- Widely used in facilities such as: pigsties, cattle barns, poultry houses, goose sheds, fruit and vegetable storage facilities, and environments with ammonia-laden atmospheres

ThermaStyle PRO





ThermaStyle PRO

ThermaStyle PRO is a wall sandwich panel featuring an expanded polystyrene (EPS) core, designed to be attached to a supporting structure using fasteners that remain invisible from the facade side. As a result, the surface of walls constructed using the ThermaStyle PRO system is uniform and free from visible fastening elements. ThermaStyle PRO panels can also be installed using the standard method—that is, by fastening them directly through the panel into the supporting structure, whether it be timber, steel, or reinforced concrete.

The versatile nature of the ThermaStyle PRO panel enables the rapid, highly cost-effective, and durable construction of lightweight wall systems suitable for a wide variety of applications.



Longitudinal plate connection

EUROPANELS connector,
self-drilling screws,
contact strip – 019,
PU foam,
sealing compound

Vertical plate arrangement

EUROPANELS connector,
self-drilling screws,
PU foam,
sealing compound

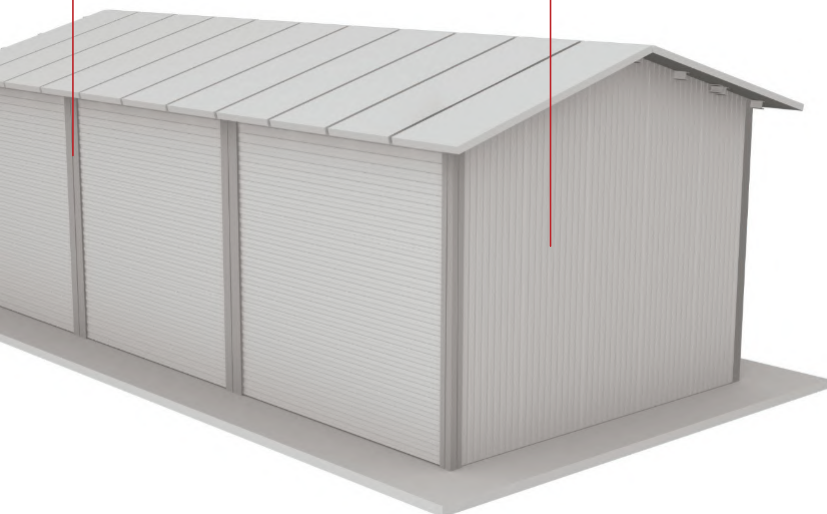

Panel cross-section

1190 mm



Available panel thicknesses [mm]

50	75	100	125	150	200	250	300
----	----	-----	-----	-----	-----	-----	-----

Thermal conductivity coefficient λD [W/(m·K)]

0.037

Heat transfer coefficient U_d, S [W/(m²·K)]

0.62	0.44	0.34	0.28	0.23	0.18	0.15	0.12
------	------	------	------	------	------	------	------

Mass 1 m² [kg]

9.4	9.8	10.2	10.6	11.1	11.9	12.8	13.6
-----	-----	------	------	------	------	------	------

Maximum number of discs per pack [pcs]

10	13	10	8	7-8	5	4-5	3
----	----	----	---	-----	---	-----	---

Plate joint cross-sections

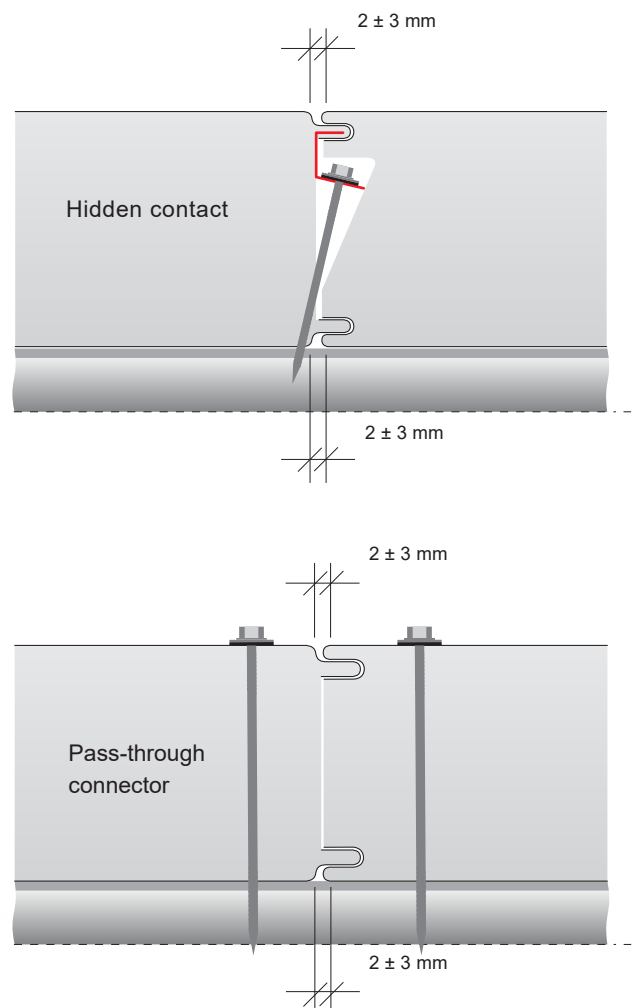

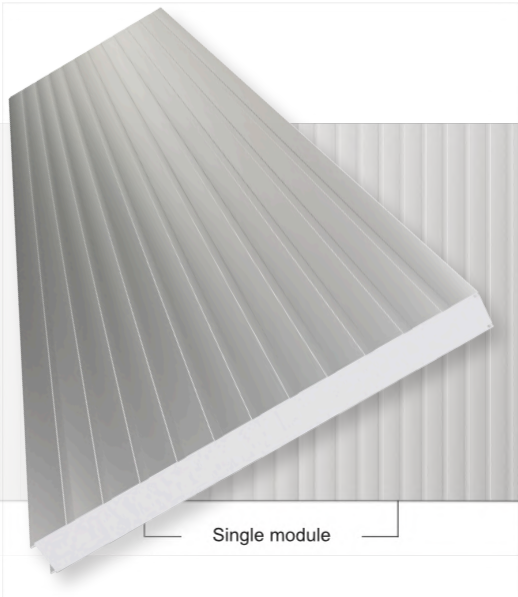

Single module

Trapezoidal
T

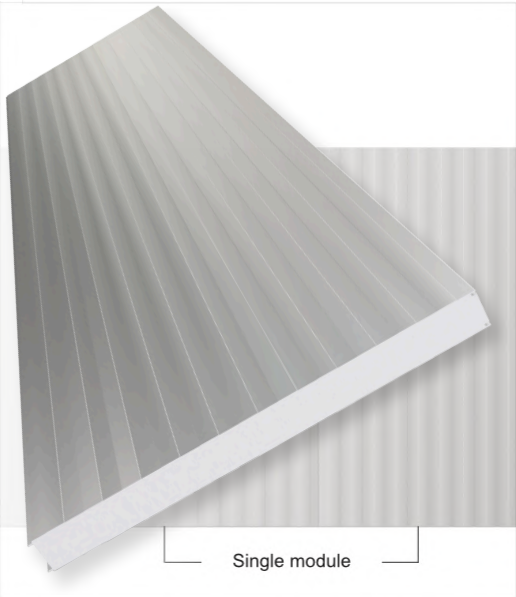

Single module

Linear
L

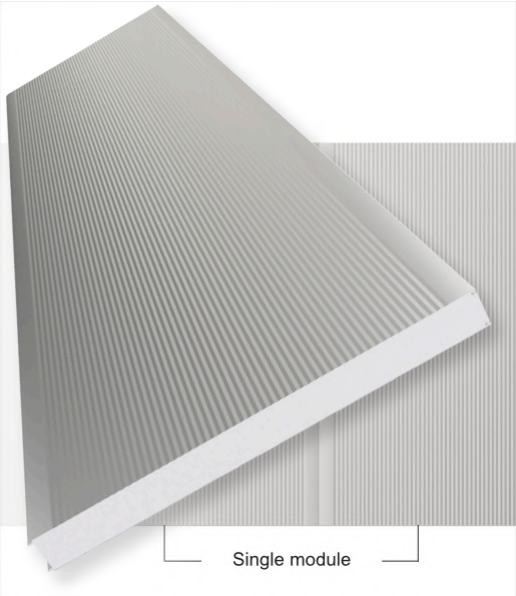

Single module

Microprofiling
M

1. MOUNTING OPTIONS – VERTICAL LAYOUT

1.1. Installation with EUROPANELS connector

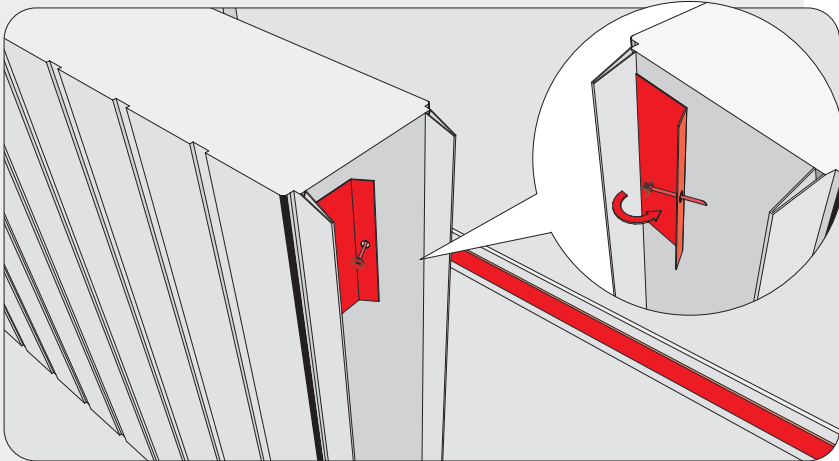

The use of the Europanel connector allows for the elimination of visible fastening elements on the building's facade. The connector is applied at the locations of the purlins (supports).

Attach acoustic tape to the surface of the purlin. Slide the Europanel-type connector into the panel's tongue. The connector curves inward into the tongue; it should rest against the panel's core. Insert an appropriate self-drilling screw from the Europanel product range into the mounting hole of the connector.

Note that the screw is driven at an angle, exiting beyond the panel's interlocking joint, in accordance with the profile of the Europanel connector.

Do not apply excessive force when fastening the panel to the purlin, to ensure that the mounting process does not result in the fracture or deformation of the panel's tongue.

1.2. Joining panels with the EUROPANELS connector

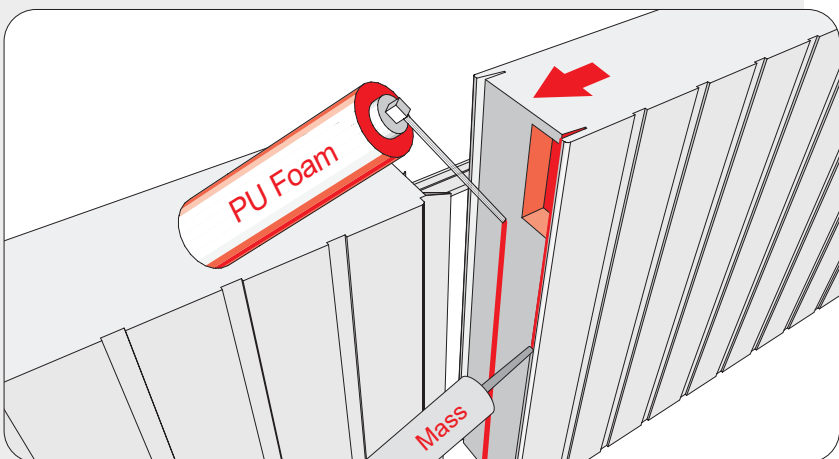

After securing the first panel, the next one should be fitted tightly into its tongue-and-groove joint. Before making the connection, use a utility knife to remove a section of the core material from the adjacent panel—specifically in the area where the Europanel fastener will be located—to create space for the fastener to recess. This step can be performed while the panels are still in the bundle (prior to installation), provided the support spacing and the length of the Europanel fastener are known; allow for a tolerance of 2 cm on each side. This procedure also applies to ThermaDeck PRO roof panels.

Assemble the panels by pressing them together firmly to ensure that the interlocking joints engage fully and the panels sit flush against one another. Next, secure the newly positioned panel to the support structure on the opposite side of the joint, as illustrated in Figure 1.1. To enhance the airtightness of the joint, a thin bead of polyurethane foam may be applied through the center of the core, and the panel joint can be further sealed using a sealant compound.

1.3. Alternative assembly

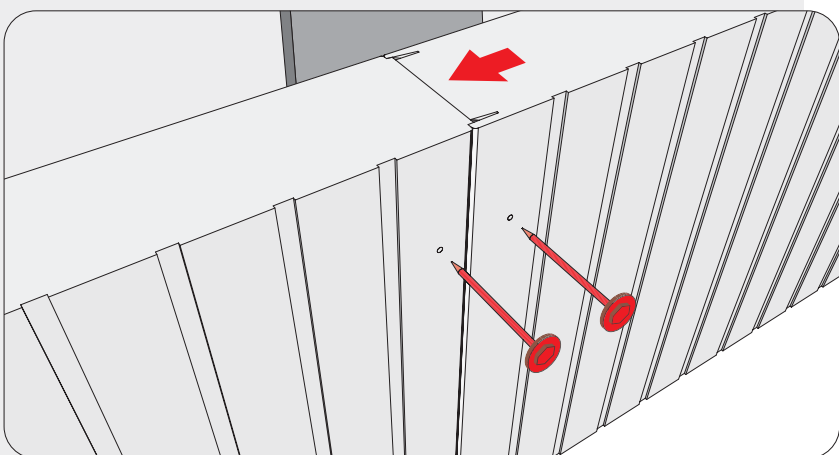

The traditional installation method involves fastening the panels directly through to the supporting structure, using only mounting screws. As a result, the screw heads will be visible on the façade; these can be concealed using suitable caps available in the Europanel product range.

Advice: When fastening the panels, try to avoid overtightening the screws, as this may result in visible deformation of the cladding (an undesirable "cupping effect"). The screw should be tightened only until the rubber washer begins to compress.

2. INSTALLATION INSTRUCTIONS FOR EPS-CORE WALL SANDWICH PANELS – THERMASTYLE PRO – FOR THE PURPOSES OF FIRE REACTION CLASSIFICATION B-s2,d0 (NRO)

2.1. Overlapping and bending of the cladding edge

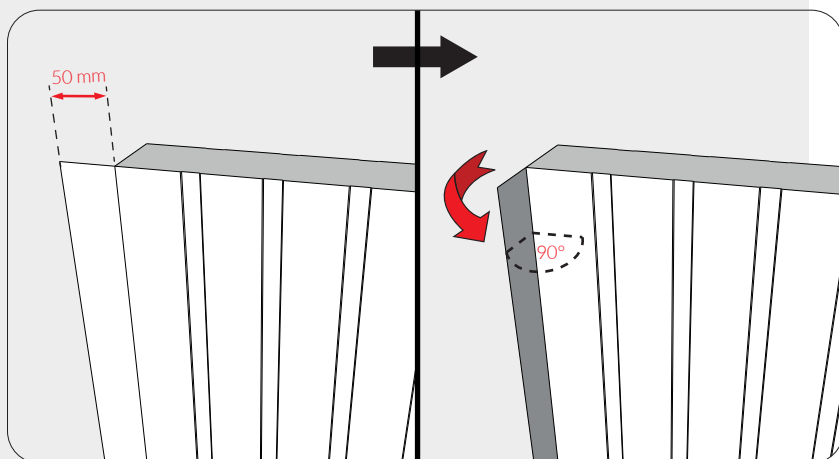

1. Panel Overlap (sheet metal lap) = 50 mm.
Corner Installation:
The protruding cladding edge extends 50 mm on the room side (inner cladding).
2. Bending the Cladding Edge by 90°. Using wooden boards or steel profiles secured to the panel along the bend line (e.g., using a protected carpenter's clamp), bend the protruding 50 mm cladding edge to a right angle.

2.2. Joining panels and securing (stitching) cladding

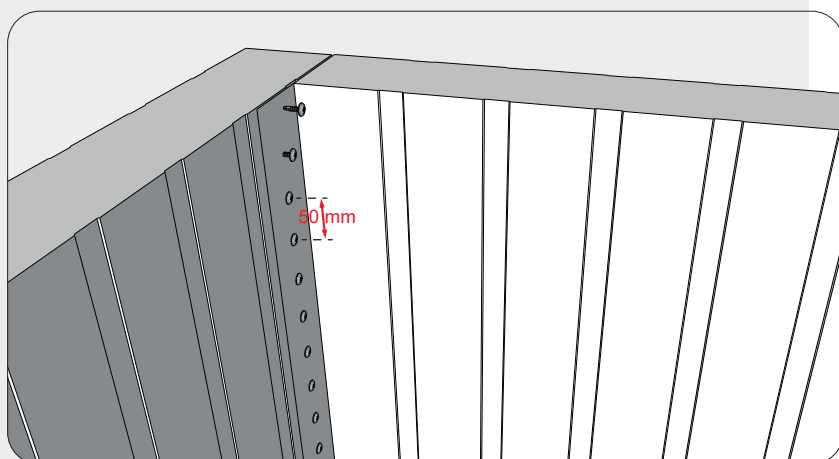

3. Joining the Panels
Push the wall elements together.
 - a. Corner installation: align flush with the outer dimensions of the panels.
 - b. Partition installation: maintain a right angle on both sides of the elements.
4. Fastening (Stitching) the Cladding
Using 4.2 x 13 mm self-drilling sheet metal screws with a flat head (PH2), stitch the panel cladding at intervals of 50 mm. Maintain an even stitching line centered along the width of the bent cladding.

2.3. Finishing works

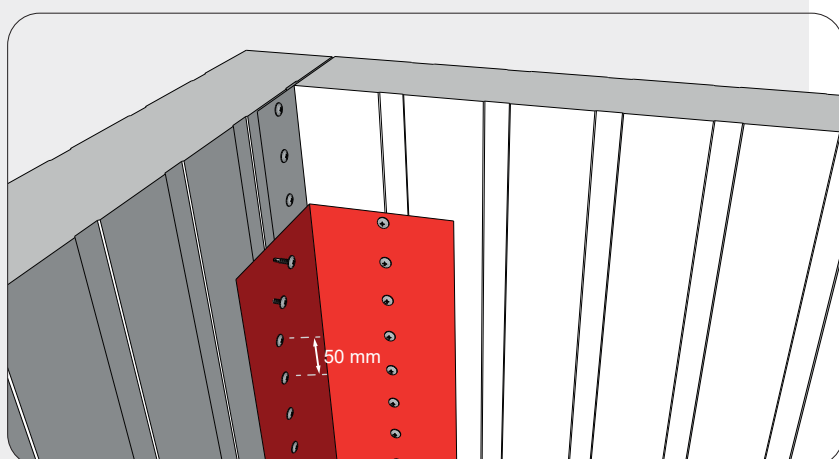

5. Finishing Works
Using 4.2 x 13 mm self-drilling sheet metal screws with a flat head (PH2), fasten the cladding panels to the 100 x 100 x 0.5 mm angle flashing. Perform the fastening on both sides of the flashing at intervals of 50 mm. Maintain an even fastening line positioned along the centerline of the flashing. On the side containing the screws installed in Step 4, apply the fasteners in a staggered pattern (resulting in an effective spacing of 25 mm between sheet metal screws).

ThermaDeck PRO





ThermaDeck PRO

ThermaDeck PRO are roof sandwich panels featuring an EPS polystyrene core. They can be attached to the supporting structure using a system consisting of a concealed Europanels fastener and a screw (known as concealed fastening), or directly using a through-screw (known as visible fastening).

ThermaDeck PRO panels are designed for use as roof coverings in all types of buildings where the roof slope in the direction of drainage is at least 4° (7%) for a covering consisting of a single panel (up to 7 m in length), or 6° (10%) for panels joined lengthwise, those installed with skylights, etc.

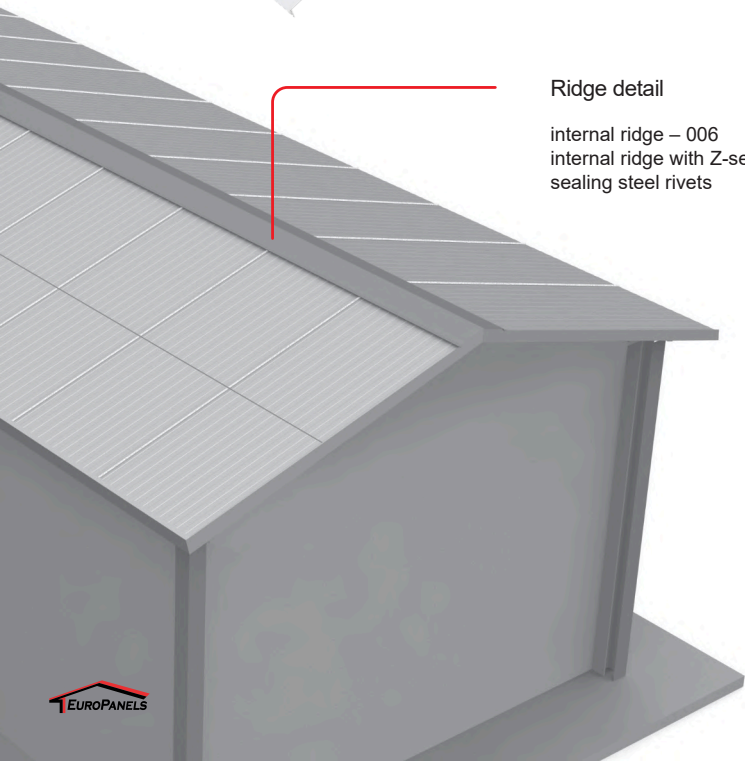
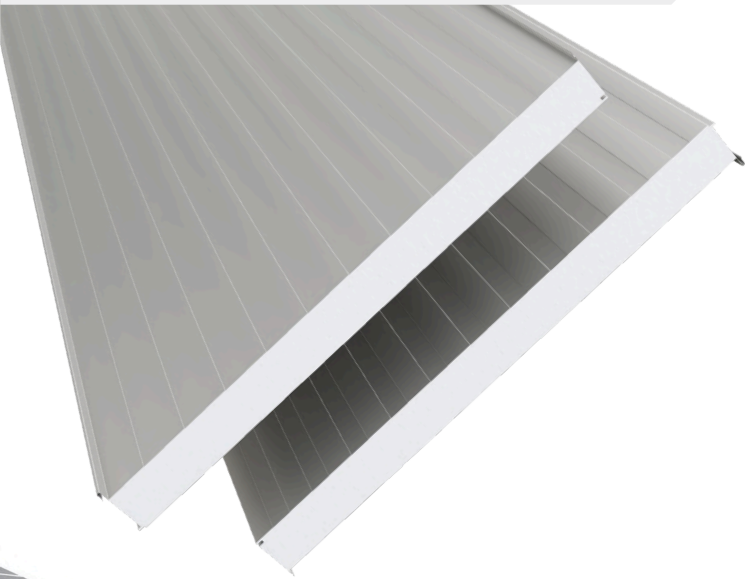

Ridge detail

internal ridge – 006
internal ridge with Z-section – 005A
sealing steel rivets

Panel cross-section

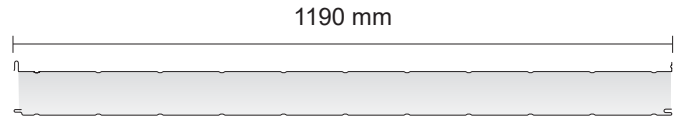

Available panel thicknesses [mm]

75	100	150	200	250	300
----	-----	-----	-----	-----	-----

Thermal conductivity coefficient λD [W/(m·K)]

0.037

Heat transfer coefficient U_d, S [W/(m²·K)]

0.46	0.36	0.24	0.18	0.15	0.12
------	------	------	------	------	------

Mass 1 m² [kg]

10.2	10.6	11.1	11.9	12.8	13.6
------	------	------	------	------	------

Maximum number of discs per pack [pcs]

7-8	7-8	6	4-5	4	3
-----	-----	---	-----	---	---

Plate joint cross-sections

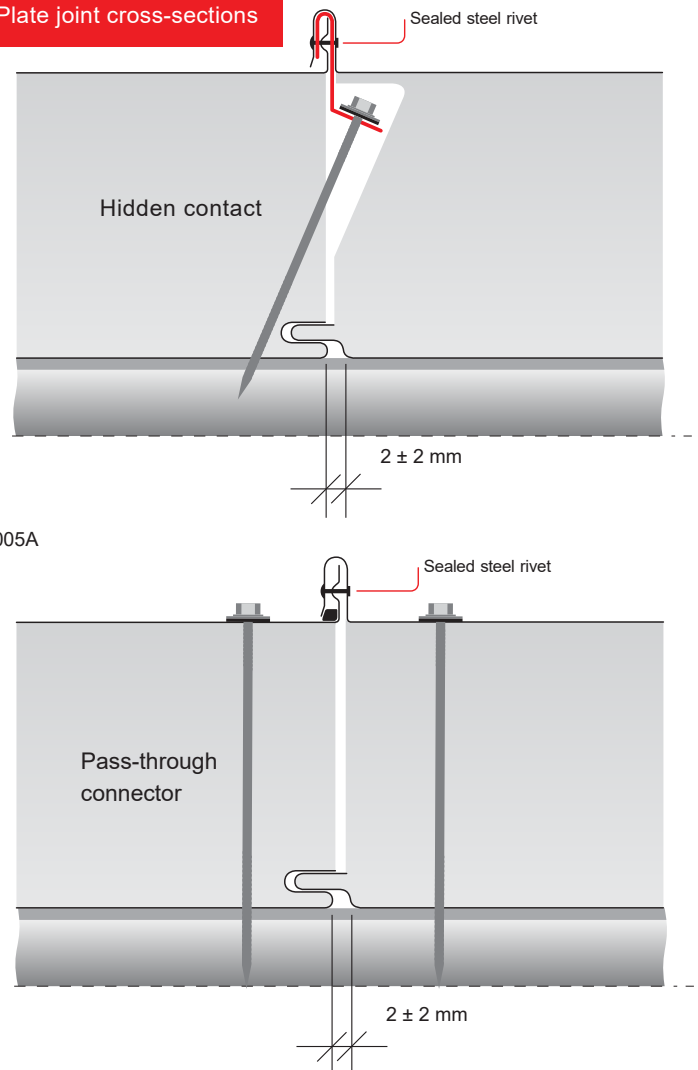

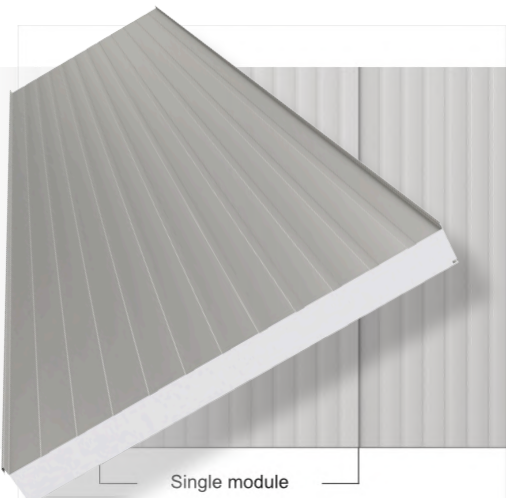

Trapezoidal
T

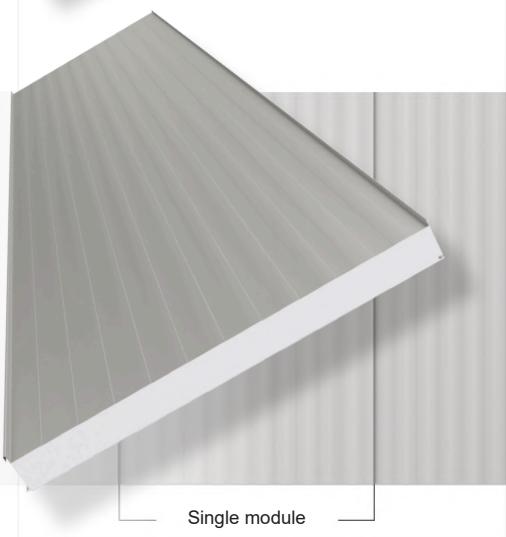

Linear
L

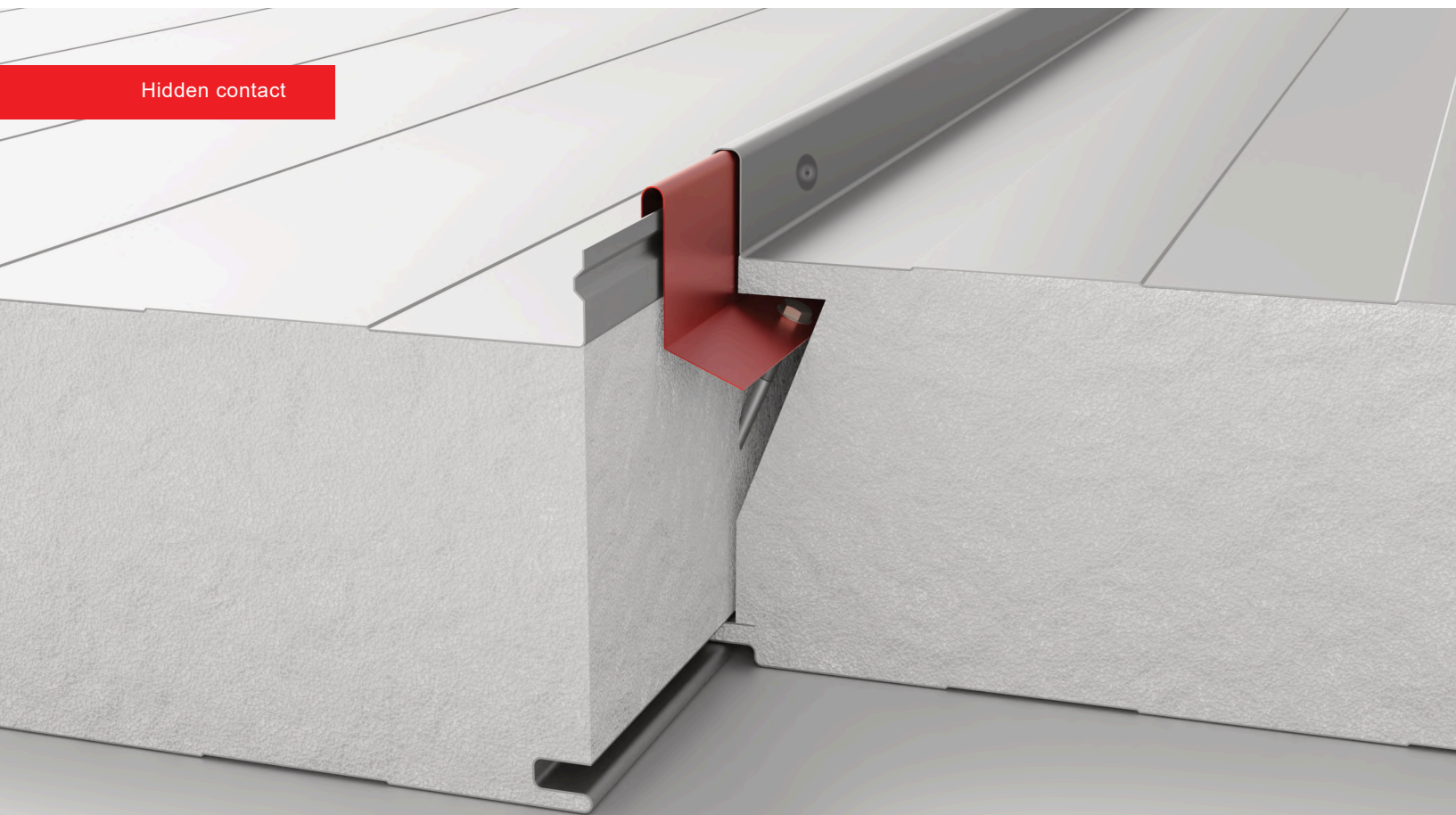

Hidden contact

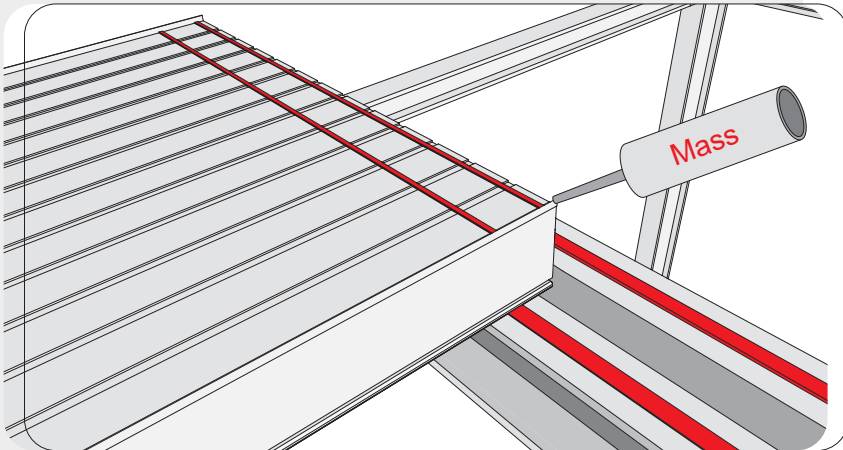
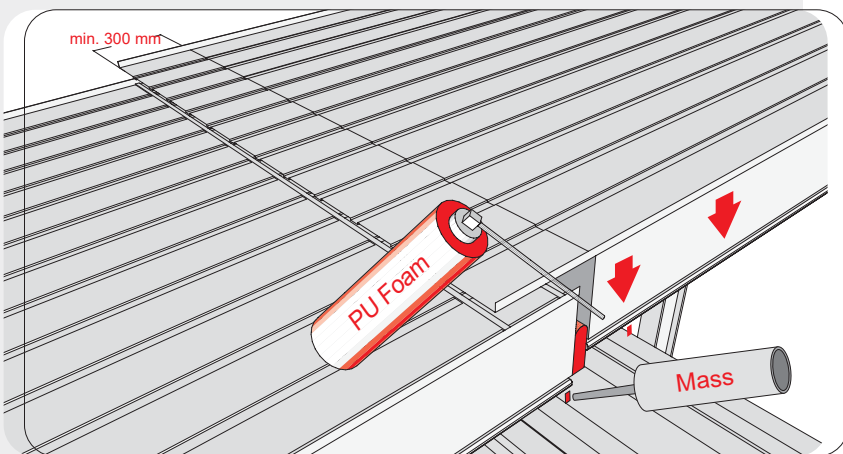
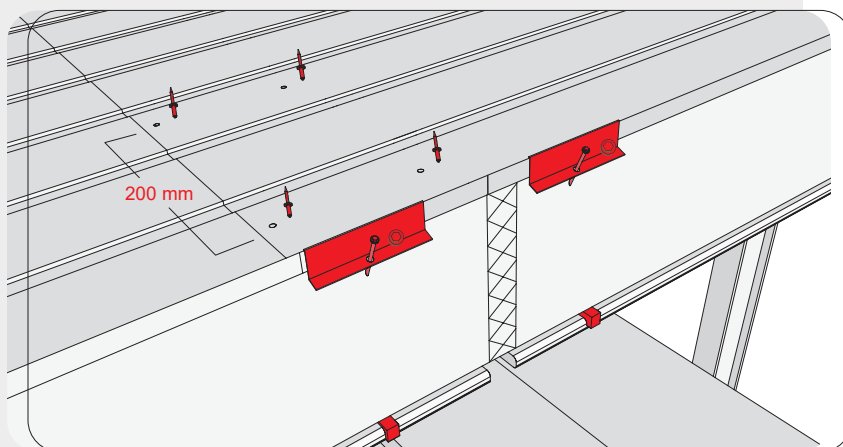
1. JOINING BOARDS ALONG THEIR LENGTH**1.1. Preparing the first panel****1.2. Installation of the overlap plate****1.3. Final assembly**

For roof slopes exceeding 7 meters in length, for technical and operational reasons, it is recommended to divide the total length into shorter sections and join them on a double purlin, while maintaining an expansion gap.

This is due to the thermal expansion and contraction of the sandwich panels under the influence of solar radiation. For this reason, the color selection for roof panels should be limited to Color Group I (very light colors; RAL 9010 is recommended).

Apply acoustic tape to the purlins of the supporting structure. Panels joined lengthwise should be installed in the direction running from the gutter toward the ridge. Position the first panel on the structure with its standing seam facing the direction of installation. Apply butyl sealant along the edges of the overlap joints.

Overlap panels feature a so-called "recess," which involves cutting through the inner facing and a portion of the panel's core. Prior to installation, remove the cut-away sections of the inner facing and core so that, ultimately, only the steel facing overlap flange (the sheet metal itself) remains. The overlap length is a minimum of 300 mm; this length increases as the roof pitch decreases.

Specific application details are determined by the project designer.

Place the overlap panel—prepared in this manner—onto the preceding panel, maintaining a 20 mm gap between the panels (expansion joint). Fill the expansion gap with low-expansion mounting foam. Seal the lateral joint between the panels using a sealant compound.

Now, the panels must be secured to the supporting structure. First, fasten the outer facings of the panels within the overlap fold. To do this, use steel sealing rivets, spaced in two rows to align with the sealant strips: one row along the edge of the overlap and another at the panel joint. The spacing between rivets should be 200 mm.

Next, position the Europanels fasteners onto the standing seams of the panels at the locations of the purlins. Secure them to the structure using the appropriate screws from the Europanels product range. Install and fasten subsequent panels in accordance with the designated installation direction, repeating the steps from the previous stages.



Advice: The final stage of assembly involves riveting the seams using steel sealing rivets at the locations of the Europanels fasteners. Any metal shavings generated during the drilling of holes must be thoroughly removed!

2. ThernaDeck PRO RIDGE SOLUTION

2.1. Installation of Z-profiles

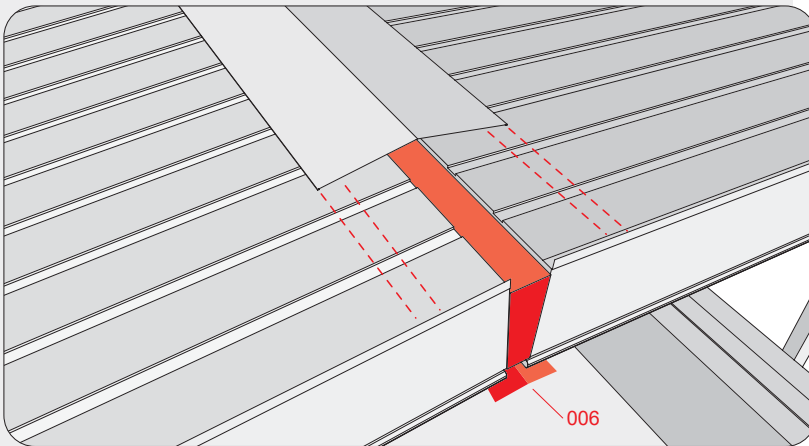

2.2. Installation of the overlap plate

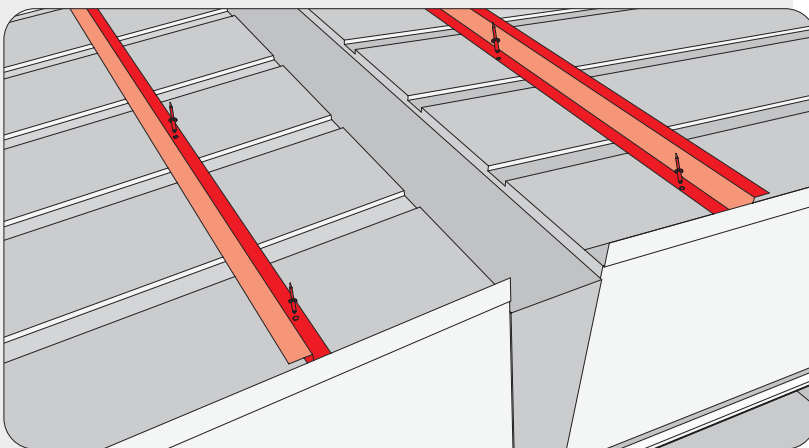

2.3. Ridge installation 005A

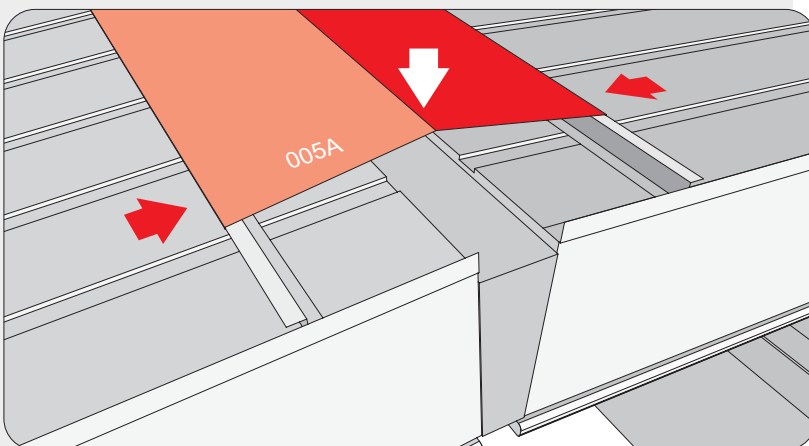

The ridge of a gable roof can be finished in a variety of ways. The method presented below is based on flashing kit 005A—an external ridge cap combined with a Z-flashing. This specific choice is recommended due to the standing and folded seams characteristic of ThernaDeck PRO panels.

At the ridge junction, the roof panels must maintain a 20 mm expansion gap between their inner facings. Fill the void between the panels with expanded polystyrene or low-expansion mounting foam. Once the roof panels have been secured, attach the internal ridge flashing (flashing element 006) to the inner facings of the panels.

To determine the mounting line for the Z-flashing, position the external ridge cap against the panel facings (aligning it exactly as it is intended to cover them in the final assembly) and mark the mounting location for the Z-flashing.

Position Z-section 005 along the designated line and fasten it with steel sealing rivets. Pay close attention to the mounting orientation of the Z-section; it must cover the interior of the ridge, thereby facilitating its installation (by allowing it to slide over the Z-section's edge). The rivets are then concealed by the Z-section (facing towards the interior of the ridge).

Finally, install the outer ridge cap. Begin at one edge by sliding it into the Z-profile. Then, secure the opposite side by sliding it into the second Z-profile. To facilitate this, you may press down on the crown of the ridge cap to guide its edge into the Z-profile. Once secured, the ridge cap should fit snugly against the edges of both Z-profiles. If the ridge cap is too loose, you must adjust the positioning of one of the Z-profiles.

SHEET METAL FLASHING

Modern dual CNC bending machine

Europanel is equipped with best-in-class, state-of-the-art, computer-controlled automatic folding machines. These machines are operated via a touchscreen interface, where the desired profile is first sketched out, followed by the precise adjustment of dimensions and angles. Next, the bending sequence is simulated to eliminate any potential collisions between the edges being folded. Finally, the prepared metal sheets are fed into the machine, and moments later, a finished component is produced—executed exactly according to the entered data under the supervision of an operator. The sheet metal is gripped by hydraulically controlled "fingers," bent in both directions (upward and downward), and automatically repositioned with exceptional precision.

Specifications:

- Steel sheet thickness: up to 1.5 mm
- Aluminum sheet thickness: up to 2.0 mm
- Minimum flat section: 15 mm
- Maximum length of finished element: 6.4 m
- Maximum sheet input width: 1250 mm
- Maximum bending angle: 140°
- Capability to produce multiple elements simultaneously (e.g., 3 × 2 m; 2 × 3 m)

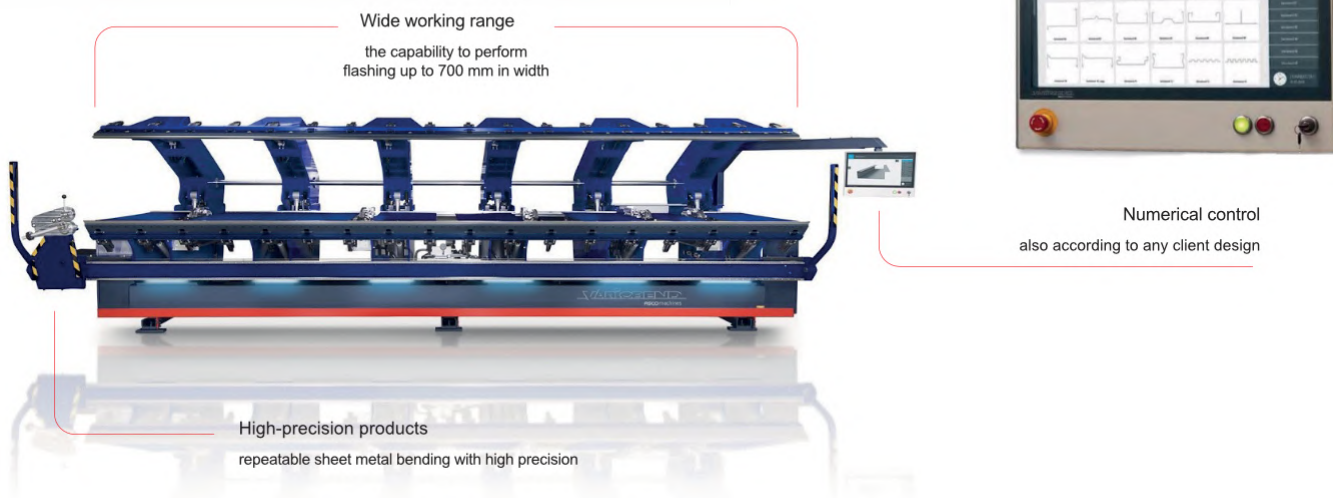

Why you should order flashings from Europanel

- Rapid production of standard flashings from the Europanel catalog, tailored to the range of available panels
- Capability to manufacture custom flashings based on client-provided drawings
- 100% dimensional repeatability (particularly crucial for ensuring uniform lengths and bending angles during serial production)
- Customizable lengths for manufactured elements (up to a maximum of 6.4 m)
- Each element can feature a tapered end, enabling a seamless longitudinal connection (the flashings overlap by 50 mm, thereby compensating for the sheet metal thickness and ensuring a flush outer edge)
- Capability to manufacture non-standard flashings with highly intricate shapes

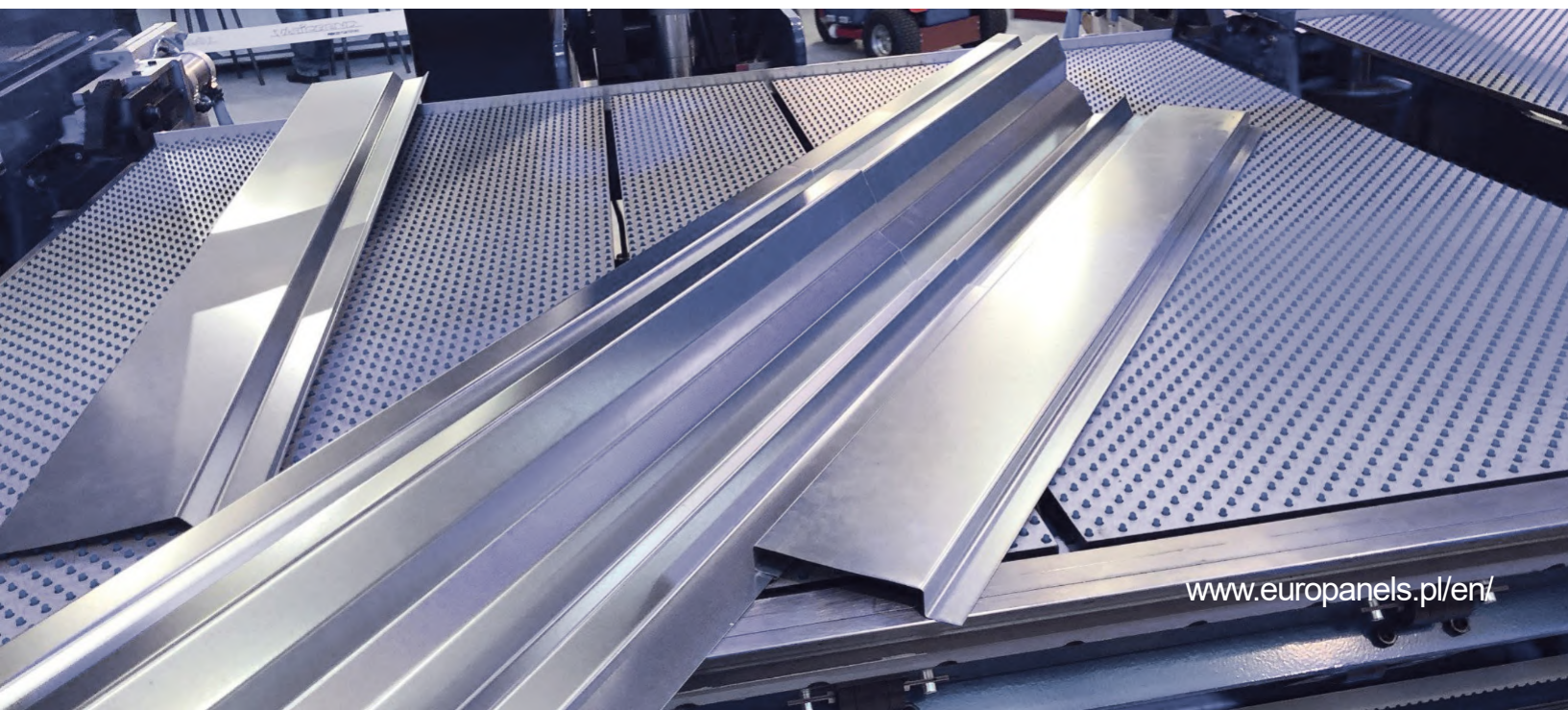
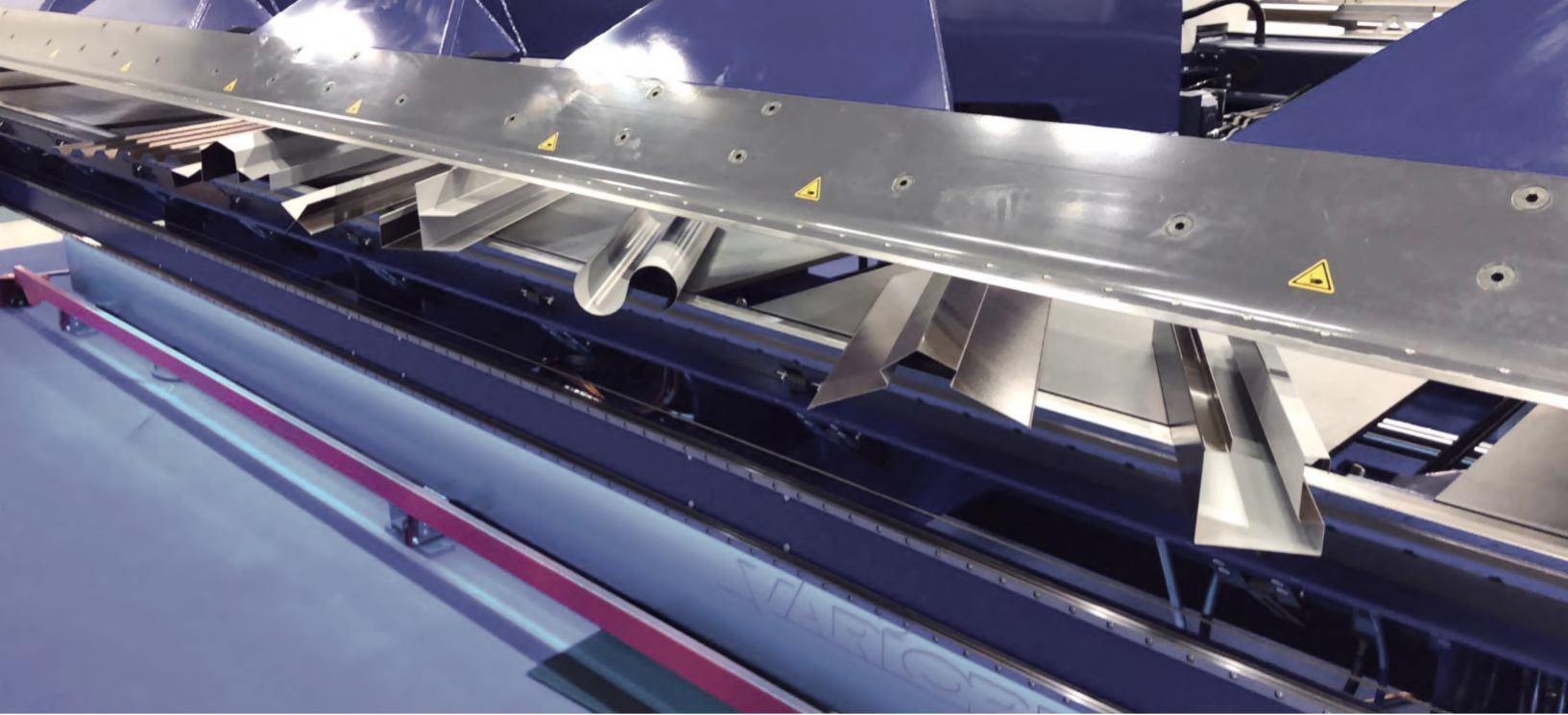

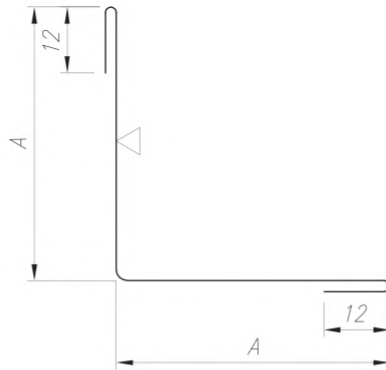

Internal corner bracket 50

Cat. No.: 001

For panels:
 PolTherma CS
 PolTherma DS
 PolTherma PS
 PolTherma TS
 ThermaStyle PRO

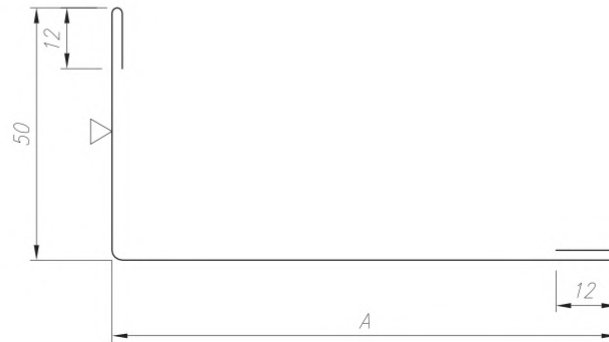

External corner 70

Cat. No.: 002

For panels:
 PolTherma CS
 PolTherma DS
 PolTherma PS
 PolTherma TS
 ThermaStyle PRO

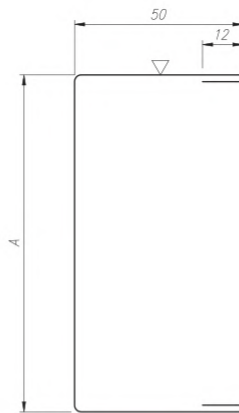

Cover channel

Cat. No.: 004

For panels:
 PolTherma CS
 PolTherma DS
 PolTherma PS
 PolTherma TS
 ThermaStyle PRO

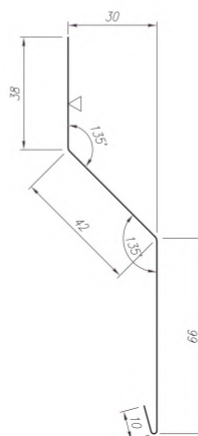
Cover strip
 Cat. No.: 008A

For panels:
 PolTherma CS
 PolTherma DS
 PolTherma PS
 PolTherma TS
 ThermaStyle PRO

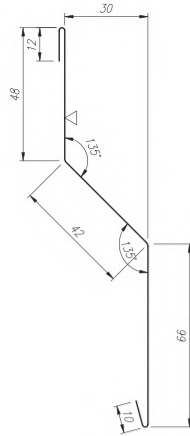

Cover strip
Cat. No.: 008B

For panels:
PolTherma CS
PolTherma DS
PolTherma PS
PolTherma TS
ThermaStyle PRO

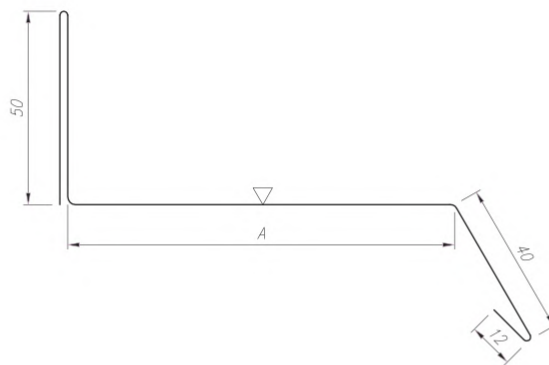

Cover strip
Cat. No.: 013

For panels:
PolTherma CS
PolTherma DS
PolTherma PS
PolTherma TS
ThermaStyle PRO

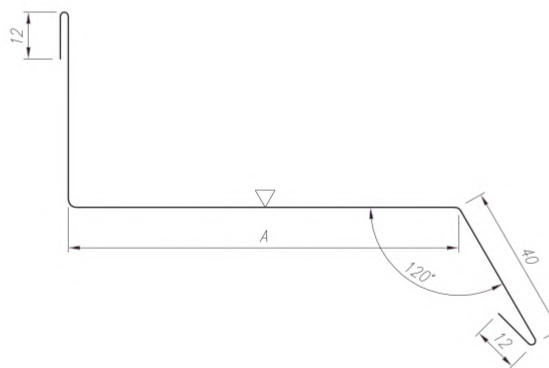

Cover strip
Cat. No.: 013A

For panels:
PolTherma CS
PolTherma DS
PolTherma PS
PolTherma TS
ThermaStyle PRO

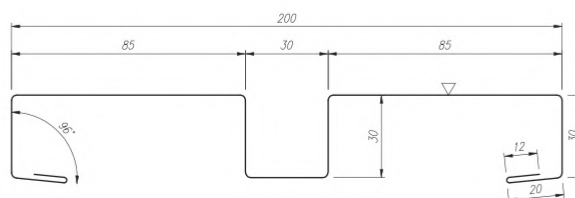
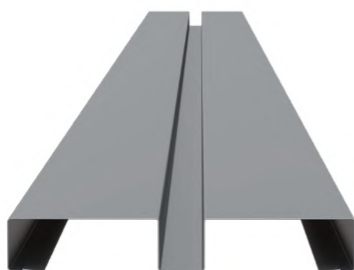

Grooved joint strip
Cat. No.: 015

For panels:
PolTherma CS
PolTherma DS
PolTherma PS
PolTherma TS
ThermaStyle PRO

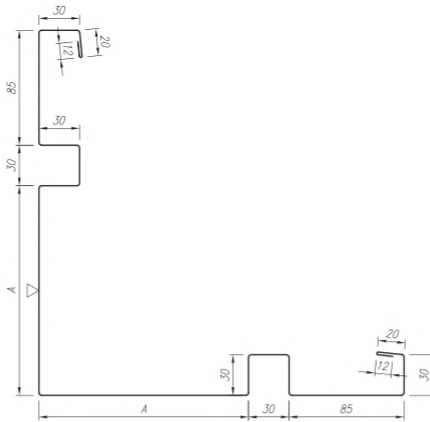
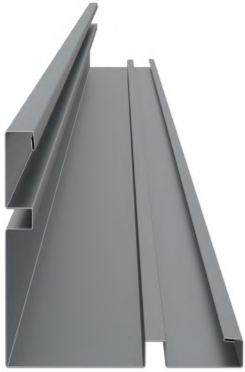

Grooved external corner profile

Cat. No.: 016

For panels:
 PolTherma CS
 PolTherma DS
 PolTherma PS
 PolTherma TS
 ThermaStyle PRO

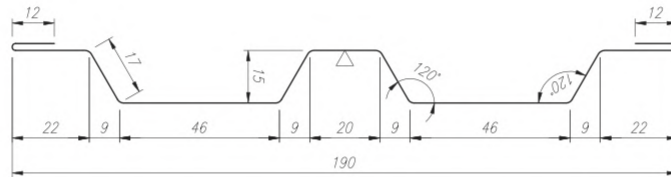
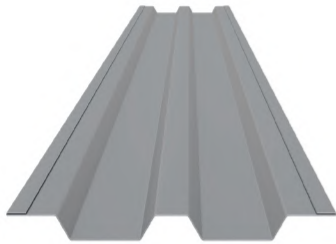

Cassette joint strip

Cat. No.: 017

For panels:
 PolTherma CS
 PolTherma DS
 PolTherma PS
 PolTherma TS
 ThermaStyle PRO

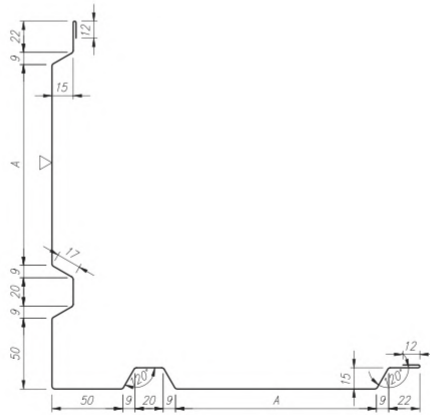
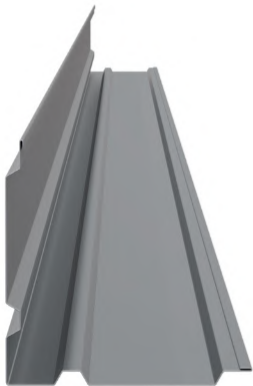

Cassette external corner profile

Cat. No.: 018

For panels:
 PolTherma CS
 PolTherma DS
 PolTherma PS
 PolTherma TS
 ThermaStyle PRO

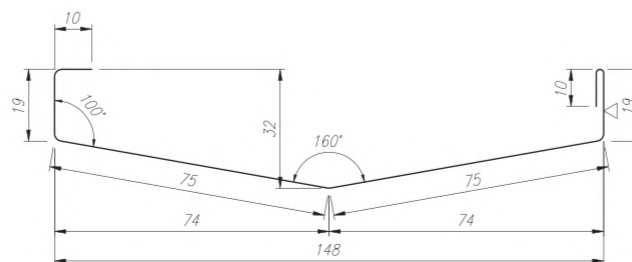
Joint strip
(concealed fixings)

Cat. No.: 019A

For panels:
 PolTherma CS
 PolTherma DS
 PolTherma PS
 PolTherma TS
 ThermaStyle PRO

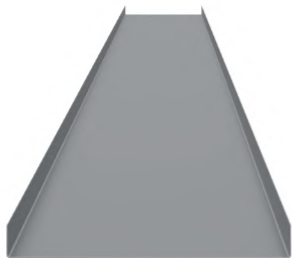

Joint strip (concealed fixings)
mounting bracket

Cat. No.: 019B

For panels:
PolTherma CS
PolTherma DS
PolTherma PS
PolTherma TS
ThemaStyle PRO

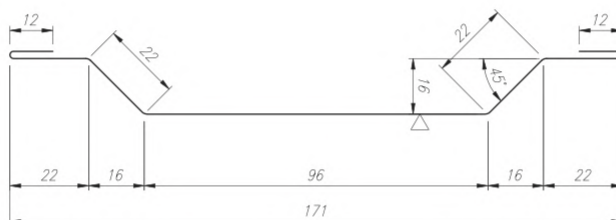
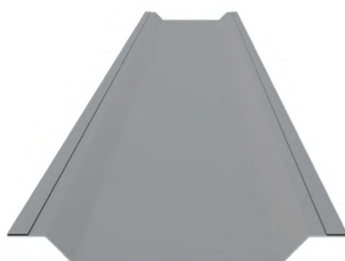

Flat joint strip

Cat. No.: 019

For panels:
PolTherma CS
PolTherma DS
PolTherma PS
PolTherma TS
ThemaStyle PRO

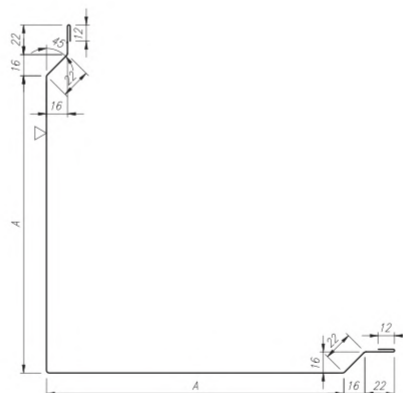
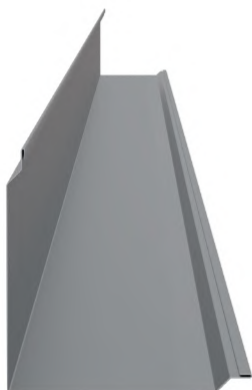

Flat external corner profile

Cat. No.: 020

For panels:
PolTherma CS
PolTherma DS
PolTherma PS
PolTherma TS
ThemaStyle PRO

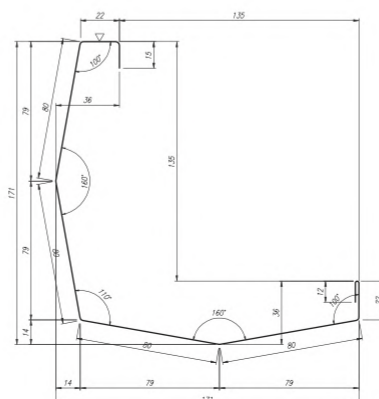
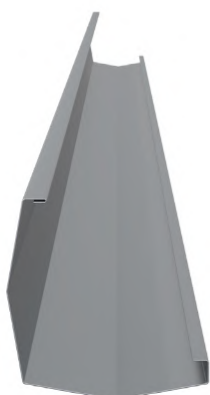

External corner profile
(concealed fixings)

Cat. No.: 020A

For panels:
PolTherma CS
PolTherma DS
PolTherma PS
PolTherma TS
ThemaStyle PRO

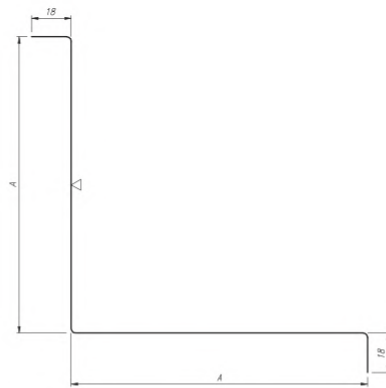
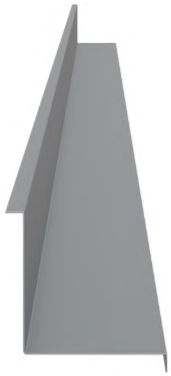

External corner profile
(concealed fixings) mounting
bracket

Cat. No.: 020B

For panels:
PolTherma CS
PolTherma DS
PolTherma PS
PolTherma TS
ThermaStyle PRO

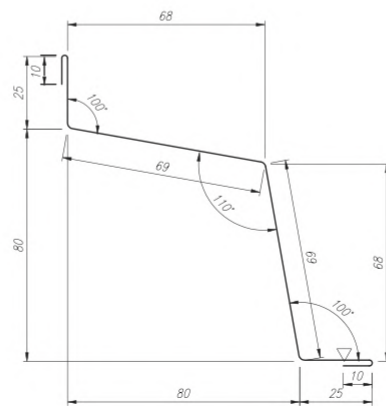

Internal plinth flashing

Cat. No.: 022

For panels:
PolTherma CS
PolTherma DS
PolTherma PS
PolTherma TS
ThermaStyle PRO

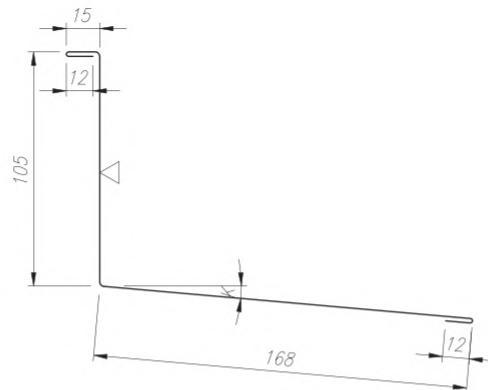
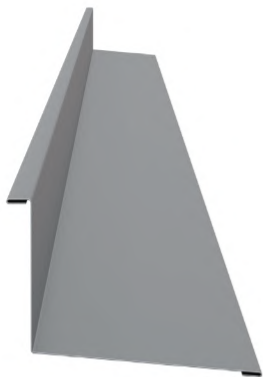

Parapet coping profile

Cat. No.: 032

For panels:
PolTherma CS
PolTherma DS
PolTherma PS
PolTherma TS
ThermaStyle PRO

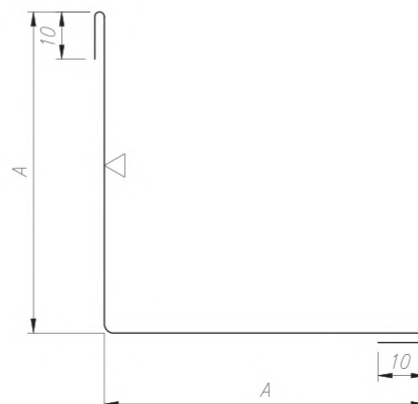

Symmetrical internal corner
profile

Cat. No.: 033

For panels:
PolTherma CS
PolTherma DS
PolTherma PS
PolTherma TS
ThermaStyle PRO

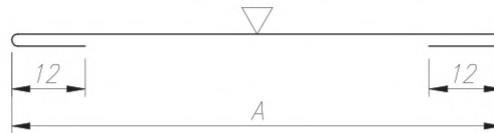
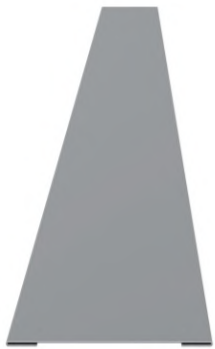

Masking joint strip

Cat. No.: 035

For panels:
 PolTherma CS
 PolTherma DS
 PolTherma PS
 PolTherma TS
 ThermaStyle PRO

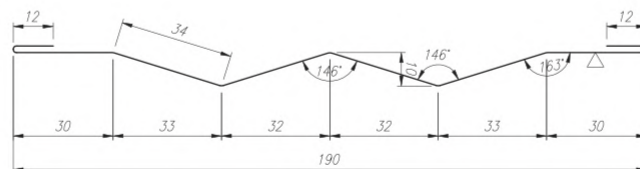
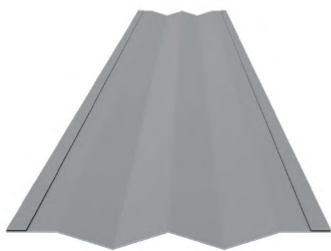

Slanted joint strip

Cat. No.: 040

For panels:
 PolTherma CS
 PolTherma DS
 PolTherma PS
 PolTherma TS
 ThermaStyle PRO

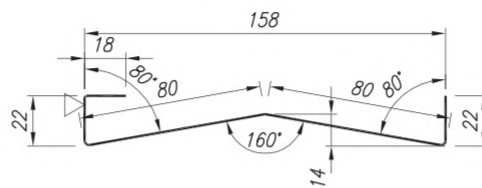

Mounting strip

Cat. No.: 044

For panels:
 PolTherma CS
 PolTherma DS
 PolTherma PS
 PolTherma TS
 ThermaStyle PRO

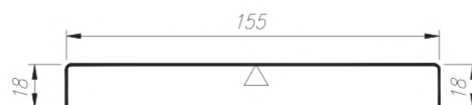

Base mounting strip

Cat. No.: 045

For panels:
 PolTherma CS
 PolTherma DS
 PolTherma PS
 PolTherma TS
 ThermaStyle PRO

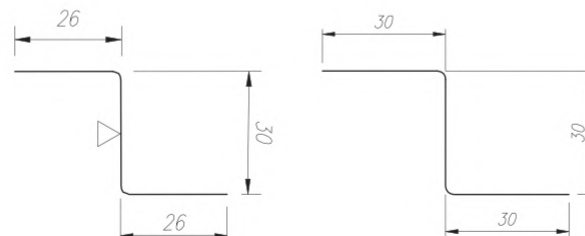
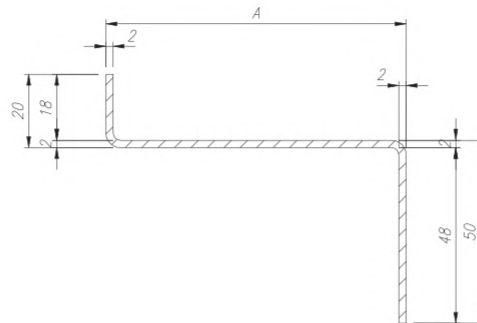
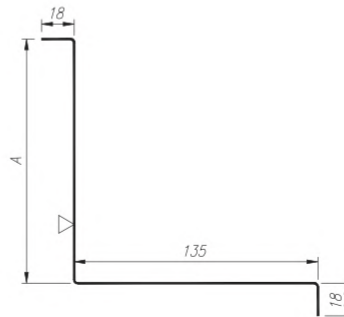
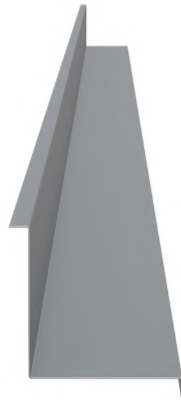
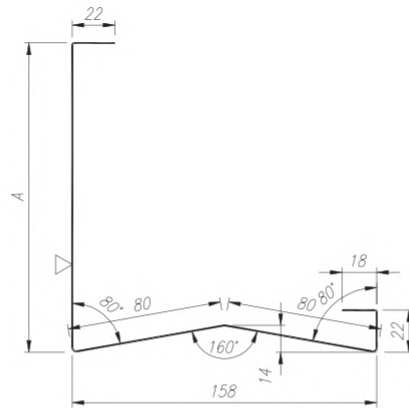

External corner profile

Cat. No.: 046

For panels:

PolThema CS

PolThema DS

PolThema PS

PolThema TS ThernaStyle

PRO

External corner profile (base)

Cat. No.: 047

For panels:

PolThema CS

PolThema DS

PolThema PS

PolThema TS ThernaStyle

PRO

Starter strip for DS and PS panels

Cat. No.: 048

For panels:

PolThema DS

PolThema PS

Z-profile 26/30/26

For flashings: 005A

Z-profile 30/30/30

For flashings: 009A

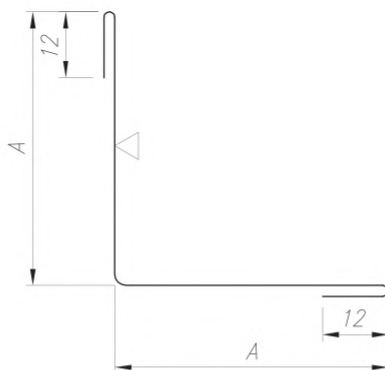

Internal corner bracket

Cat. No.: 001

For panels:
PolDeck TD
ThermaDeck PRO

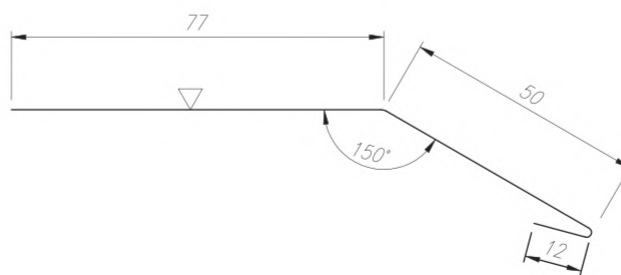

Drip edge

Cat. No.: 003

For panels:
PolDeck TD
ThermaDeck PRO

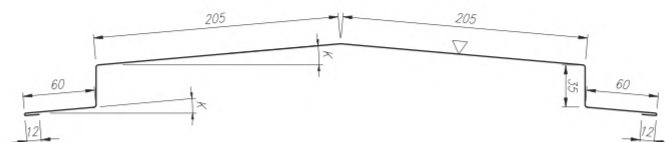
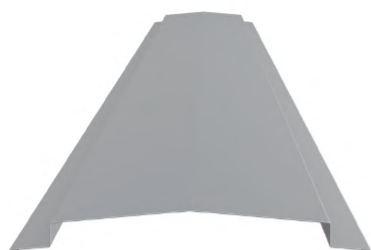

External ridge profile

Cat. No.: 005

For panels:
PolDeck TD
ThermaDeck PRO

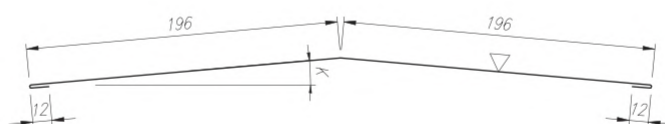

External ridge profile
(with Z-profile)

Cat. No.: 005A

For panels:
ThermaDeck PRO

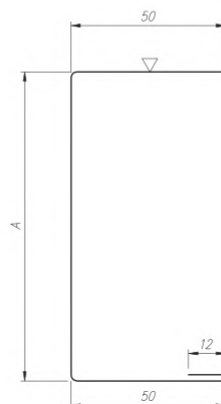
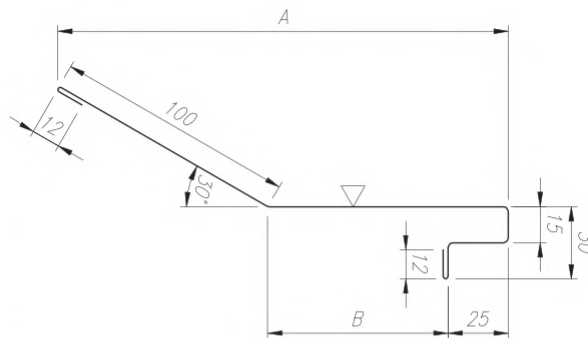
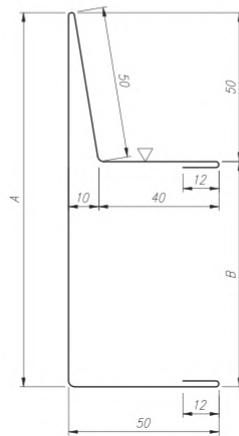
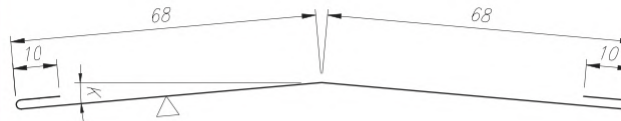

Internal ridge profile

Cat. No.: 006

For panels:
PolDeck TD
ThermaDeck PRO

Gable corner profile (cover element)

Cat. No.: 007

For panels:
PolDeck TD
ThermaDeck PRO

Gable corner profile (cover element)

Cat. No.: 007A

For panels:
ThermaDeck PRO

U-channel closing profile

Cat. No.: 009

For panels:
PolDeck TD
ThermaDeck PRO

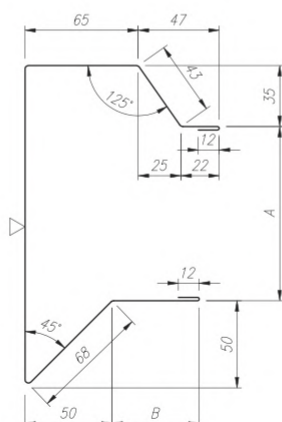
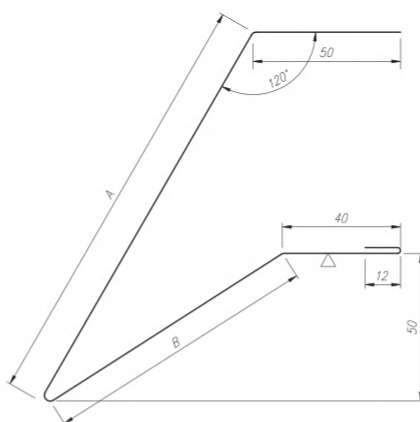
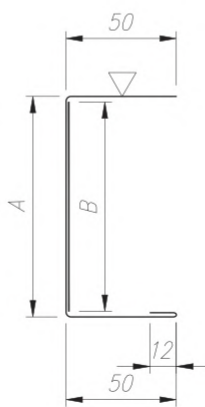
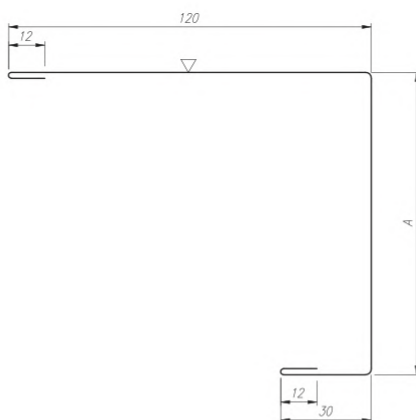

U-channel closing profile

Cat. No.: 009A

For panels:
ThermaDeck PRO

U-channel closing profile

Cat. No.: 009B

For panels:
PolDeck TD
ThermaDeck PRO

Cover drip edge

Cat. No.: 011

For panels:
PolDeck TD
ThermaDeck PRO

End closure strip

Cat. No.: 024

For panels:
PolDeck TD

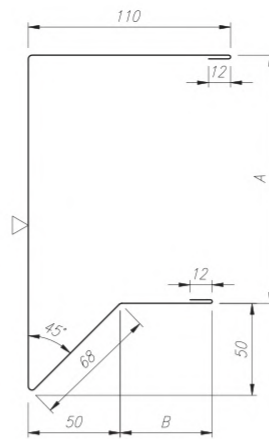

End closure strip

Cat. No.: 025

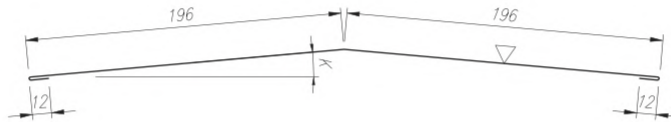
For panels:
PolDeck TD

External ridge profile

Cat. No.: 027

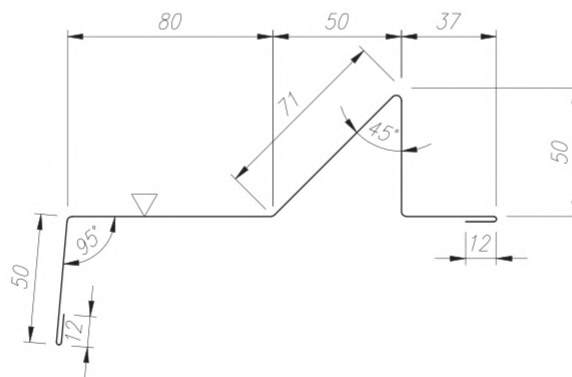
For panels:
PolDeck TD

Eaves flashing

Cat. No.: 028

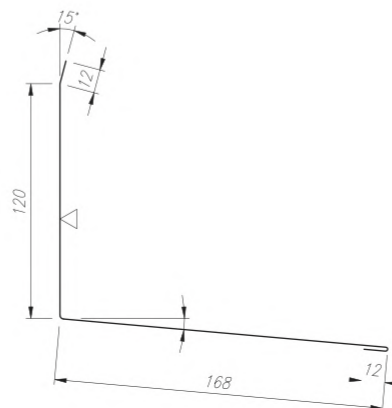
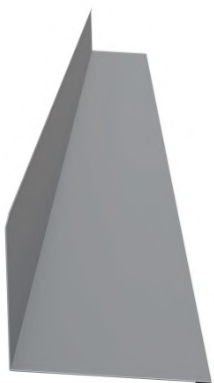
For panels:
PolDeck TD

Parapet coping profile

Cat. No.: 030

For panels:
PolDeck TD
ThermaDeck PRO

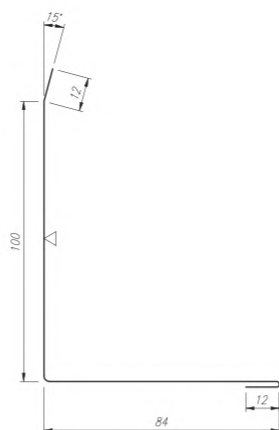

Parapet coping profile

Cat. No.: 031

For panels:
PolDeck TD
ThermaDeck PRO

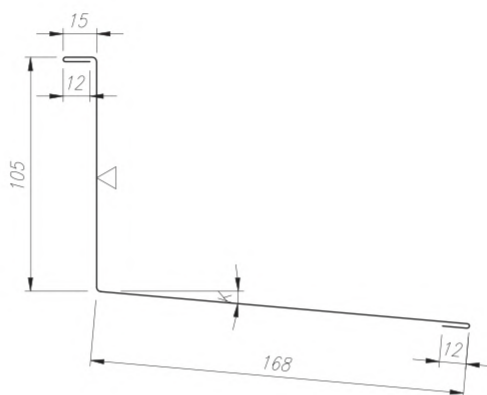
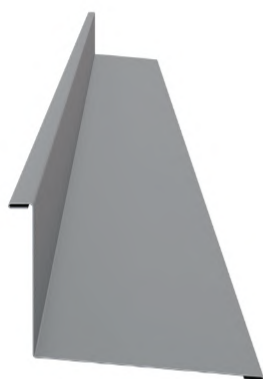

Parapet coping profile

Cat. No.: 032

For panels:
PolDeck TD
ThermaDeck PRO

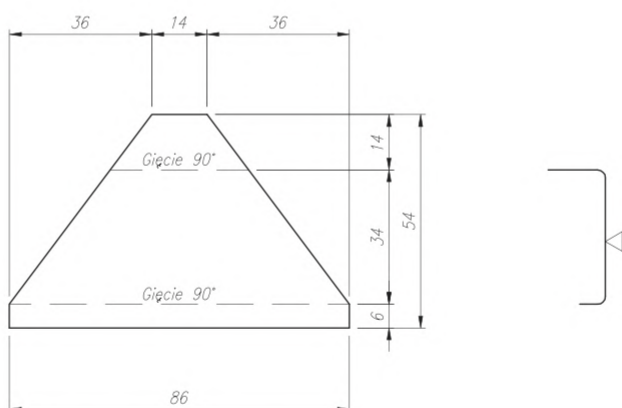

End cap
Cat. No.: 034

For panels:
PolDeck TD

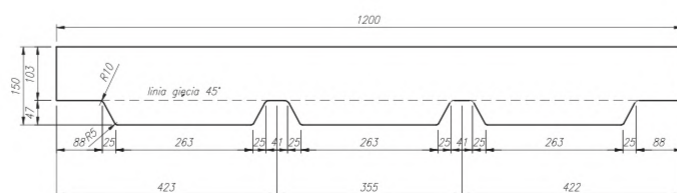

Ridge profile
Cat. No.: 038

For panels:
PolDeck TD

CLADDING COLORS

The cladding colors offered by Europanel have been classified into three groups based on relative lightness, as defined in the PN-EN 14509 standard. The assignment of specific colors to these groups is determined by the solar energy accumulation on their surface relative to the reflectivity of a magnesium oxide surface. Due to the potential for increased surface heating of the panels during periods of intense sunlight, we recommend using light colors (Groups I and II) for the external metal sheeting—particularly for roof panels. The colors shown below are for illustrative purposes only; actual products may vary slightly.

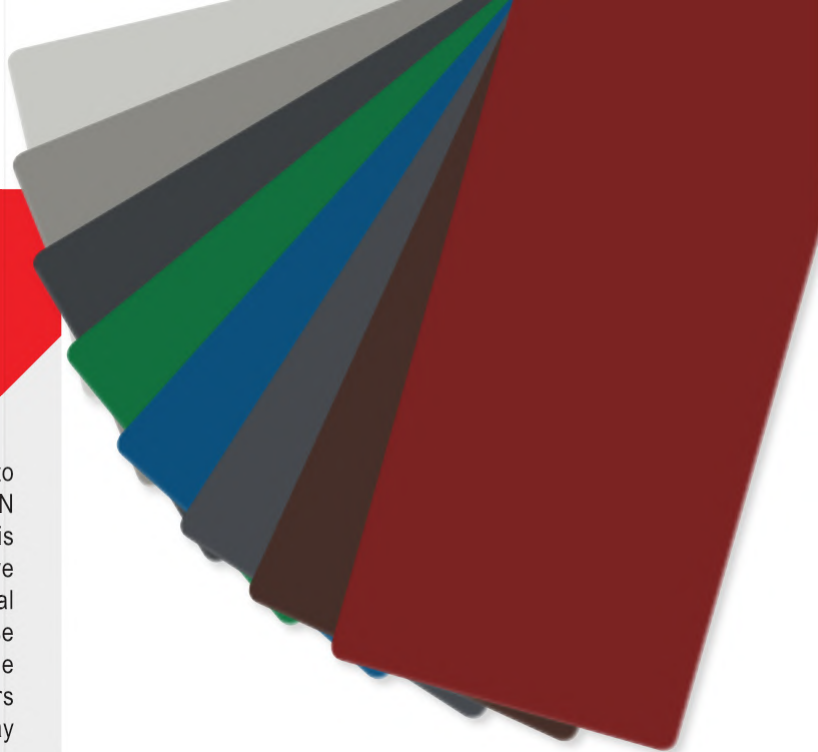

Dostępne kolory:

RAL 9010
white
group I (very bright)



RAL 9002
gray and white
group I (very bright)



RAL 7035
light gray
group I (very bright)



RAL 9006
metallic silver
group II (bright)



RAL 9007
grey aluminum
group III (dark)



RAL 3009
red oxide
group III (dark)



RAL 7016
anthracite grey
group III (dark)

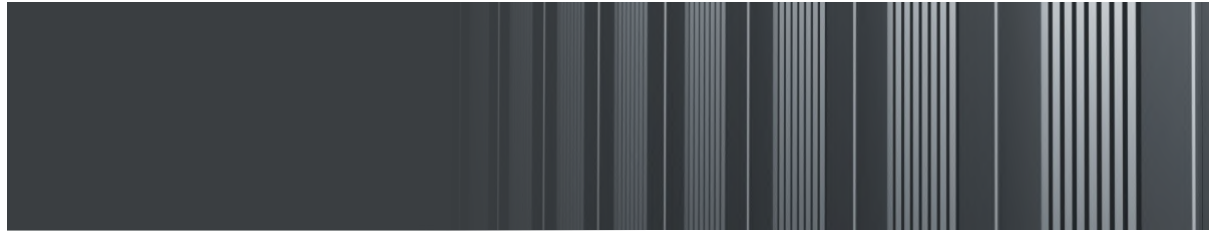

RAL 6029
mint green
group III (dark)



RAL 5010
blue
group III (dark)



RAL 7024
graphite gray
group III (dark)

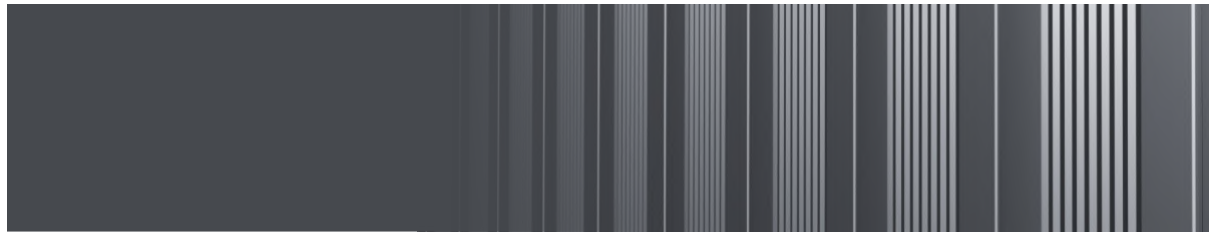

RAL 8017
brown
group III (dark)



RAL 8004
brick red
group III (dark)



RAL 3011
red
group III (dark)



INNOVATIVE CLADDING COLORS

If you dream of a facade that catches the eye while helping you save on additional elements, our cladding is the perfect solution for you. Choose natural patterns that will give your building a unique character.

You can choose from wood-effect and stone-effect cladding available in a wide range of shades. Our products combine both aesthetics and functionality.

Don't wait! If you are interested, send us a message or give us a call. Our team will be happy to answer all your questions and assist you in selecting the best solution for your project.

WALNUT LIGHT

WALNUT DARK

SONOMA OAK

BLEACHED OAK

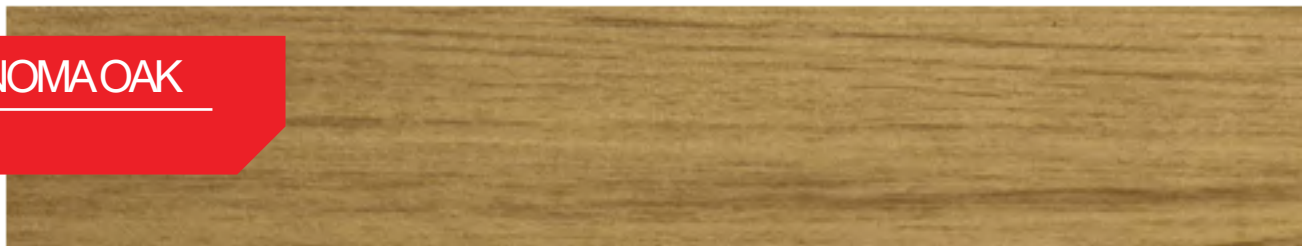
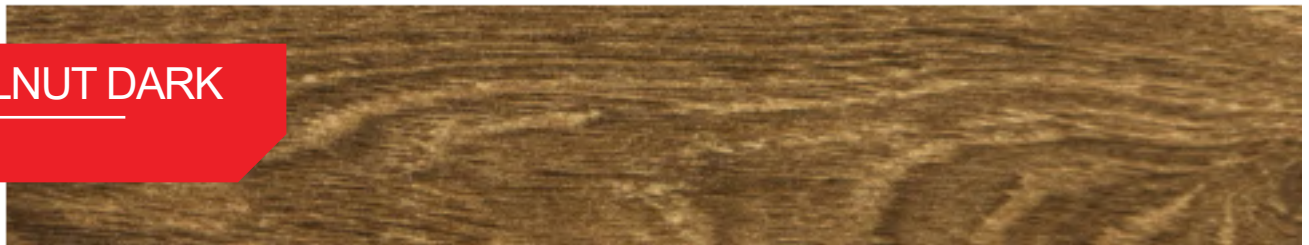



SAND STONE



OSAKA GRAY



CLASSIC CORTEN
STEEL



ARCHITECTURAL
CONCRETE



RUST SLATE



RUST MOSAIC



RUST PATINA



EuroPanels Sp. z o.o.
Inflancka 5/81 St., 00-189 Warsaw
NIP: 5252463541 | KRS: 0000326849 | REGON: 141978067

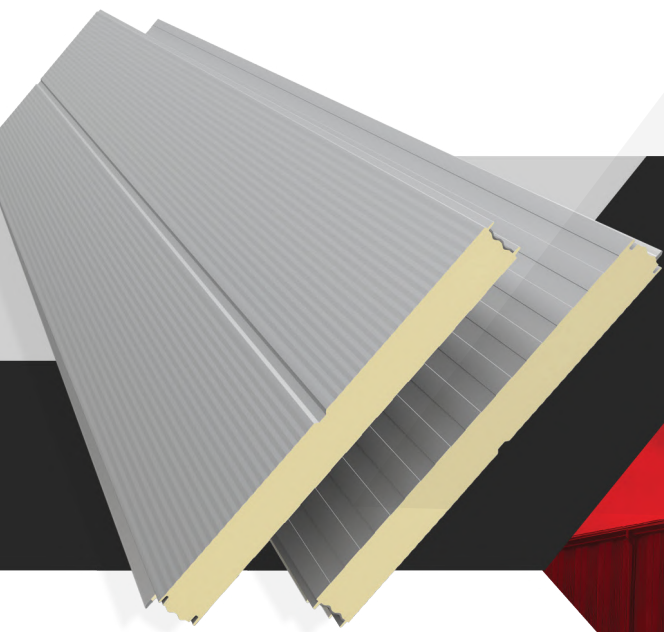

EPS Production Facility

Sales Department
Toruńska 85 St., 87-800 Włocławek

☎ +48 602 308 546

✉ export@europanels.pl

PU Production Facility

Sales Department
Łatkowo 35, 88-100 Inowrocław

☎ +48 602 308 546

✉ export@europanels.pl



www.europanels.pl/en/

Edition: 03.2026 © Copyright by Europanels 2024. All rights reserved. This brochure does not constitute technical documentation. The content and drawings presented herein are for illustrative purposes only. The installation of panels must be carried out in accordance with the project design, and technical details are to be determined by the designer. Europanels accepts no liability for any discrepancies between the content of this brochure and the actual products. Europanels reserves the right to modify its product range without prior notice. This brochure does not constitute a binding offer within the meaning of applicable law.