

I. GENERAL CHARACTERISTICS

a. Application

PolDeck TD is a roof sandwich panel with a core made of rigid polyurethane foam PUR that is installed with the use of self-drilling screws onto the support construction (so called visible fastening). It is allowed to install the panels onto the steel, reinforced concrete and wooden constructions. PolDeck TD panel is dedicated for covering roofs in all kinds of buildings where the downward pitch of the roof is at least 4° (7%) for single panel use and 6° (10%) for panels joint lengthwise, installed with skylights etc.

PolDeck TD panels should be used in accordance to a technical design prepared for a particular building, taking into consideration technical parameters of the panels declared by the producer. Application of PolDeck TD must be in compliance with building regulations and norms, including the guidelines from the Infrastructure Ministry Directive from 12 April 2002 concerning the location and the technical conditions that a building should fulfill. (Dz. U. nr 75/2002, position. 690 with the later changes).

b. Characteristics

PolDeck TDS panel is characterized by its above-average modular width, which is 1065mm, very advantageous acoustic and durability parameters, very good thermo insulation and air and water tightness, and easiness in installation. The panels can be joined lengthwise with the use of so called overlapping.

II. PHYSICAL PROPERTIES, TECHNICAL DATA

a. Dimensions

MODULAR WIDTH (COVERING AREA) [mm]:	1065
TOTAL WIDTH [mm]:	1175
AVAILABLE LENGTHS [mm]:	minimum: standard 2800, shorter sections may be cut for an extra fee maximum 12000 (for 40/75 panels) and 18000 for the remaining thicknesses
AVAILABLE THICKNESSES (CORE/RIB) [mm]:	40/75; 60/95; 80/115; 100/135; 120/155; 145/180; 165/200
OVERLAPPING [mm]:	from 50-300 L-left and P-right

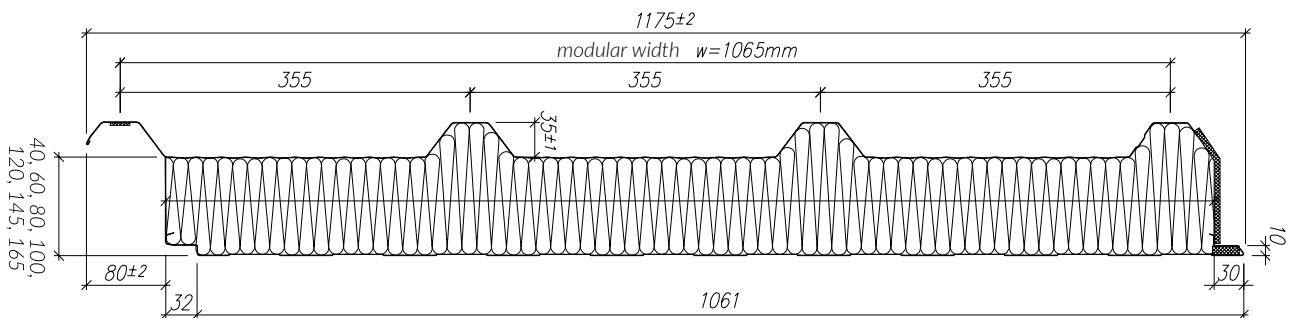

b. Outer facings profiling

Trapezoidal T35 with stiffening grooves (2 grooves between the ribs)

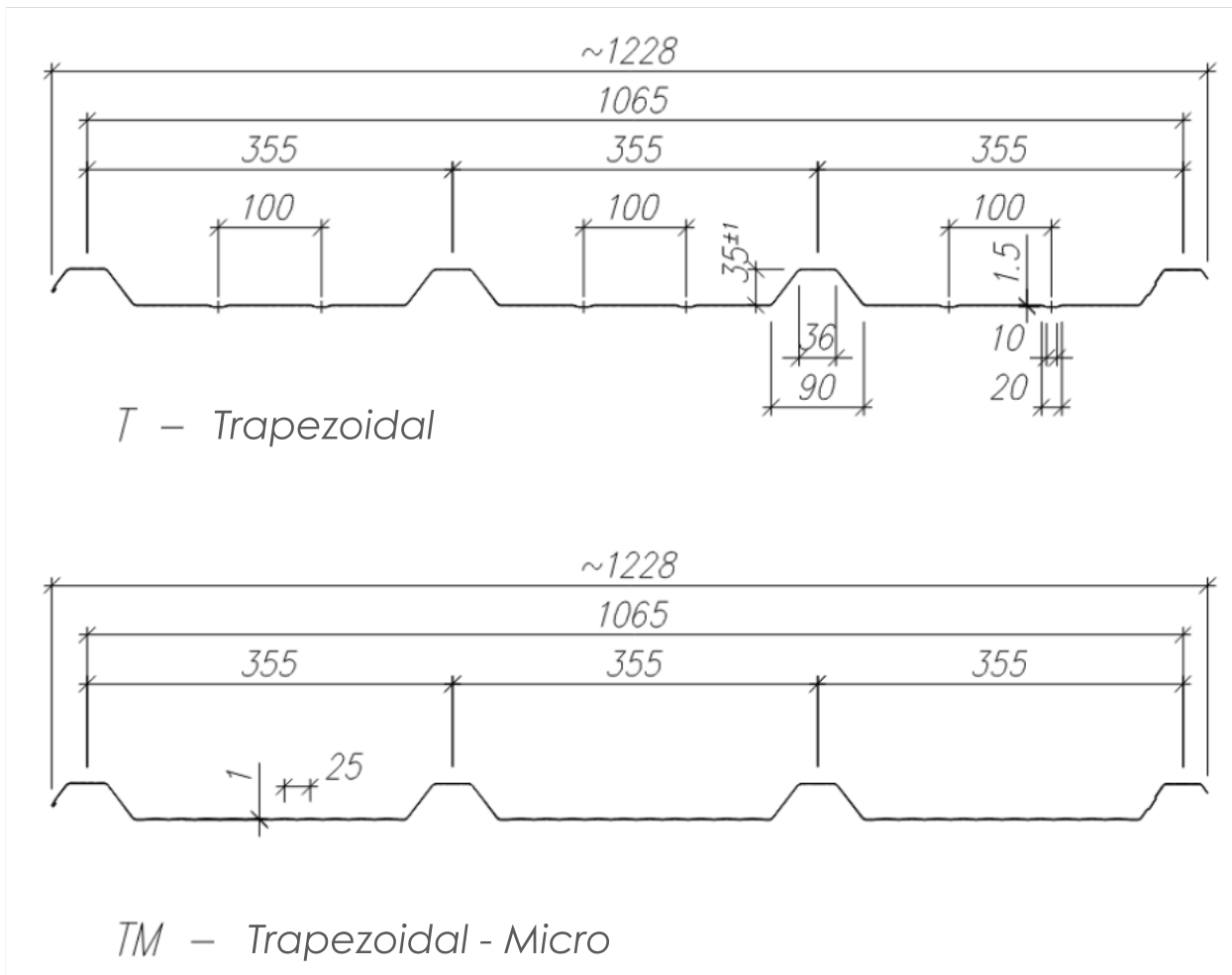

c. Inner facing profiling

Standard:

- Linear (L)

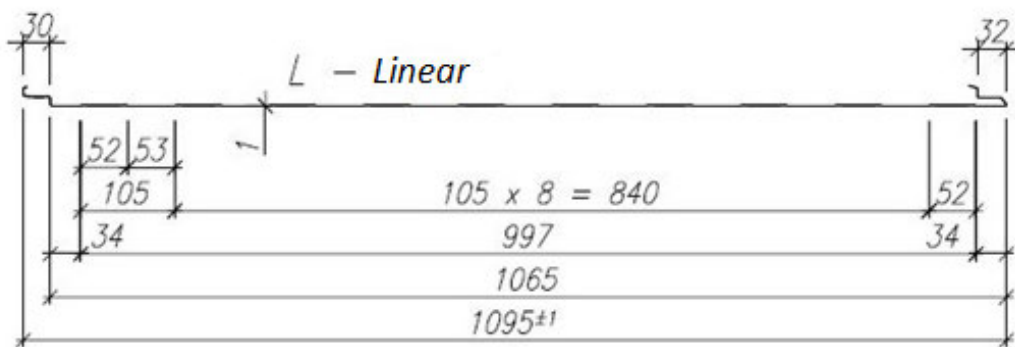

Option:

- Grooved (R), Micro-profiled (M), Flat (P)

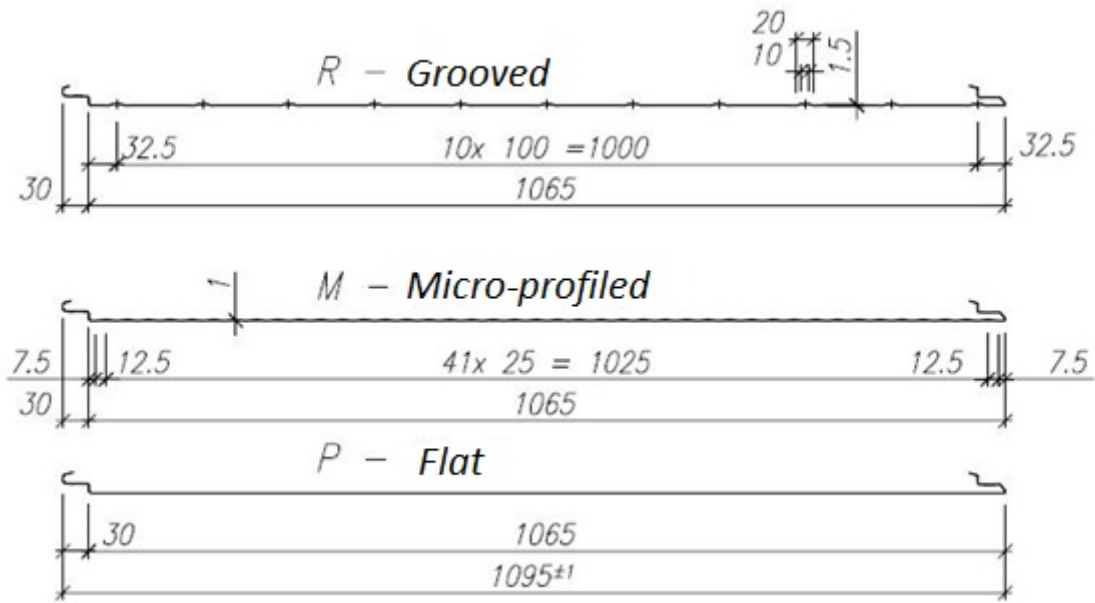

d. The panel joint

An aluminum film is applied along one edge of the panel, along the second edge of the panel a polyurethane seal reinforced with an aluminum film is applied.

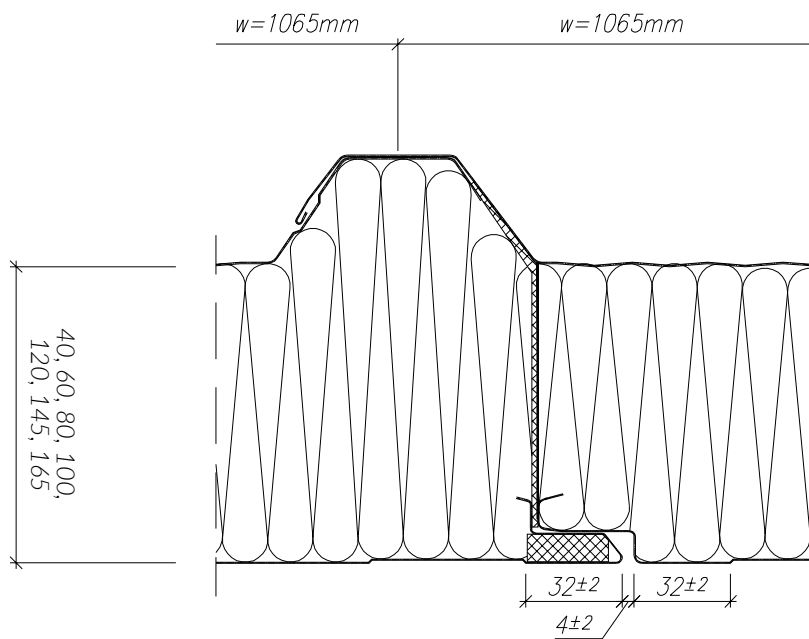

e. Mass

PANEL THICKNESS [mm]	MASS 1 m ² [kg]
40/75	10,7
60/95	11,5
80/115	12,3
100/135	13,0
120/155	13,8
145/180	14,8
165/200	15,6

f. Facings

Steel sheet 0,5 mm thick (outer facing) and 0,5 mm or 0,4mm (inner facing)

g. Core

European PU Roof System Core — rigid PU foam with declared density 38 ± 3 kg/m³ and thermal conductivity coefficient $\lambda_D = 0,022$ W/(m·K) at +10°C including aging, according to EN 14509:2013-12

h. Thermo insulation

PANEL THICKNESS [mm]	Thermal transmittance coefficient U _{d,s} [W/(m ² ·K)]
40/75	0,62
60/95	0,40
80/115	0,29
100/135	0,23
120/155	0,19
145/180	0,16
165/200	0,14

i. Acoustic parameters

REAL ACOUSTIC INSULATION:	R _w (C; C _{tr}) 26 (-2; -4) dB
SOUND ABSORPTION	$\alpha_w = 0,15$

j. Tightness

AIR TRANSMITTANCE:	$\leq 0,10$ m ³ /m ² /h
WATERPROOFNESS	Class A
VAPOR TRANSMITTANCE:	Not transmitted

k. Fire resistance

PolDeck TD panels 40 - 120 mm thick with a seal in the overlap and Promaseal mastic seal in the joint from the inner side, and rivets every 150 mm from the outside received the following classification regarding the fire resistance: REI 15 | RE 120 | R 30 (moment in the bay $M_d \leq 0,113\text{kNm}$; on the support $M_d \leq 0,201\text{kNm}$)

l. Reaction to fire

Class B-s2, d0

m. Fire spreading rate / Fire resistance of the roof to outside fire

NRO / Broof(t1)

n. Durability

Met for all color groups

o. Corrosive tests

Possible to use in environments A1, A2, A3 inside a building and C1, C2, C3 inside and outside of a building for standard galvanic surfaces Z225 and for organic SP 25

p. Loads

Load charts have been prepared for all PolDeck TD panels fastened directly onto a support construction with the use of self-drilling screws that go throughout the panel. The self-drilling screws' characteristic load capacity is 2,2 kN/pc. The charts are available on our website www.europanel.pl.

q. Dimension tolerance

THICKNESS::	± 2 mm for thicknesses 40 -100 mm; $\pm 2\%$ for thickness >100 mm
FLATNESS:	$L=0,6/1,0/1,5$ mm for $L=200/400/ > 700$ mm
LENGTH:	$L=\pm 5/10$ mm for lengths $\leq 3\ 000 / > 3\ 000$ mm
MODULAR WIDTH:	$W3 = \pm 2$ mm
RECTANGULARITY:	$\leq 0,6\% \cdot \text{modular width} = 6,4$ mm
RECTILINEARITY:	1,0 mm/m, max 5,0 mm
LONGITUDINAL BENDS:	2,0 m/m, max 10 mm
CROSSWISE BENDS:	10 mm/m

III. ADDITIONAL INFORMATION

a. Documentation and certificates

Declaration of Performance Properties CE

b. Available product options

Additional anti-condensation layer ARGO

It eliminates the risk of humidity condensation (crossing the dew point due to low temperature and high air humidity inside of a building) and its falling from the roof into the building. Thanks to its unique cell construction the ARGO layer stops the humidity in itself and in a natural way transmits it back to the atmosphere (humidity evaporates when the external conditions return to a state below the dew point). The ARGO layer does not age nor does it wear out. It is easy to clean (spraying water from a hose or a pressure washer).

Application: fruit storages, sports, production, garage or warehouse halls, agricultural buildings.

IV. TECHNICAL DRAWINGS – FLASHINGS AND RECOMMENDED SOLUTIONS

Available on our website www.europanel.pl.